

---

*Section instructor* \_\_\_\_\_*Section number* \_\_\_\_\_*Last/First name* \_\_\_\_\_*Last 3 Digits of Student ID Number:* \_\_\_\_\_

*Show all work. Show all formulas used for each problem prior to substitution of numbers. Label diagrams and include appropriate units for your answers. You may use an alphanumeric calculator during the exam as long as you do not program any formulas into memory. By using an alphanumeric calculator you agree to allow us to check its memory during the exam. Simple scientific calculators are always OK!*

*A Formula Sheet Is Attached To The Back Of This Examination*

*Be Prepared to Show your Student ID Card*

*Score on each problem:*

1. (30) \_\_\_\_\_

2. (20) \_\_\_\_\_

3. (20) \_\_\_\_\_

4. (20) \_\_\_\_\_

*Total Score (out of 90 pts)* \_\_\_\_\_

### 1. Conceptual Questions

(30 point) Put a circle around the letter that you think is the best answer.

1.1. (6pts) Two particles of the same mass enter a magnetic field with the same speed and follow the circular paths shown in the figure. Which particle has a positive/negative charge?

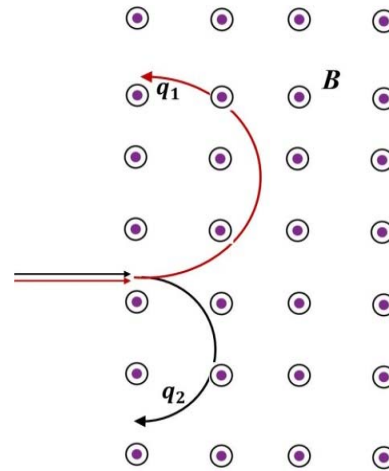

- A)  $q_1$  is negative, and  $q_2$  is negative
- B)  $q_1$  is negative, and  $q_2$  is positive
- C)  $q_1$  is positive, and  $q_2$  is positive
- D)  $q_1$  is positive, and  $q_2$  is negative
- E) they are not charged

1.2. (6pts) What is the time constant for the discharge of the capacitors shown in the figure?

- A)  $4RC$
- B)  $RC/4$
- C)  $RC$
- D)  $RC/2$

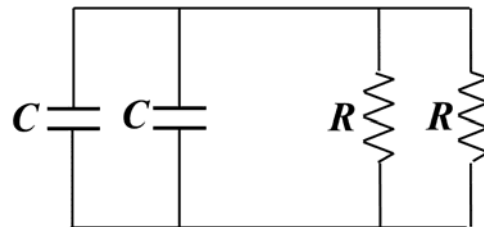

1.3. (6pts) A current-carrying wire is pulled away from a conducting loop in the direction shown. As the wire is moving, what is a direction of the induced current in the loop. (CW stands for a clockwise direction; CCW – counterclockwise)

- A) CW
- B) CCW
- C) No current
- D) None of the above

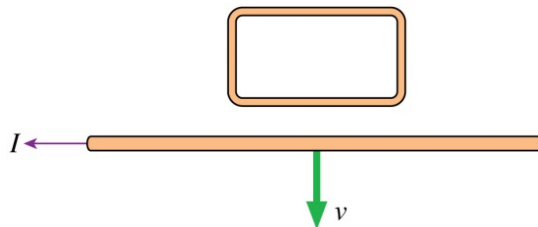

© 2013 Pearson Education, Inc.

1.4. (6pts) What is a direction of the magnetic force in the following two situations?

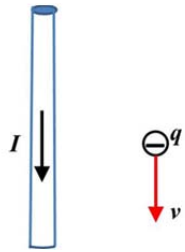

- A) no force
- B) to the left
- C) to the right
- D) into the page
- E) out of the page

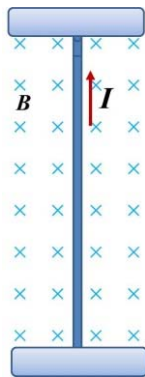

- A) no force
- B) to the left
- C) to the right
- D) into the page
- E) out of the page

1.5. (6pts) What is the direction of the magnetic field at the position of the dot equidistant to both currents?

- A) up
- B) down
- C) right
- D) left
- E) into the page

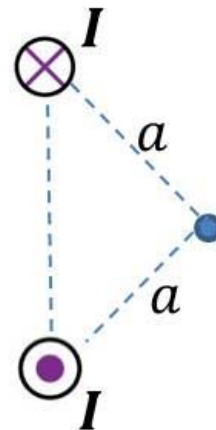

**Problem 2. (20 pts)**

- a) *What is the current in the wire to the right of the junction?  
Does the current in this wire flow to the right or to the left?*

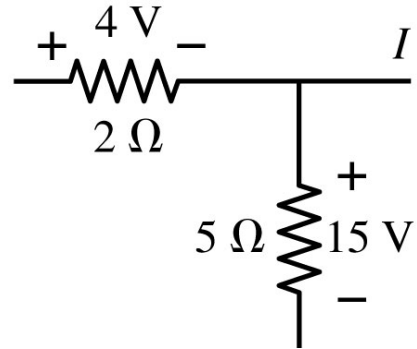

- b) *What is  $\Delta V$  across the unspecified circuit element?*

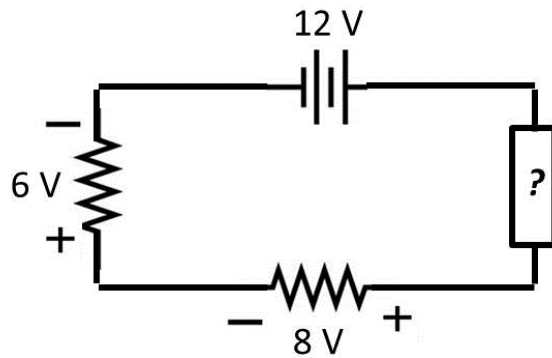

**Problem 3. (20 pts)**

*A long straight cylindrical wire conductor of radius  $R$  carries a current  $I$  of uniform current density in the conductor. Determine the magnetic field due to this current at:*

- a) Points outside the conductor ( $r > R$ ),*
- b) Points inside the conductor ( $r < R$ ),*

(Show Amperian loops; at least for one of the cases (a or b) show how you handle a linear integral)

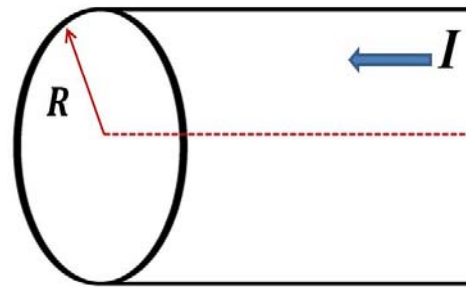

**Problem 4. (20 pts)**

A metal rod moves with constant velocity ( $v=20$  m/s) along two parallel metal rails, connected with a strip of metal at one end as shown in the figure. An induced current appears in the direction shown (CCW) and equals to  $I_{ind}=0.1A$ . The rails are separated by  $l=0.1m$ . The resistance of the loop is  $R=10\Omega$ . The whole structure is exposed to the external uniform constant magnetic field perpendicular to the page.

- What is the direction of the external magnetic field?
- What is the strength of the external magnetic field?

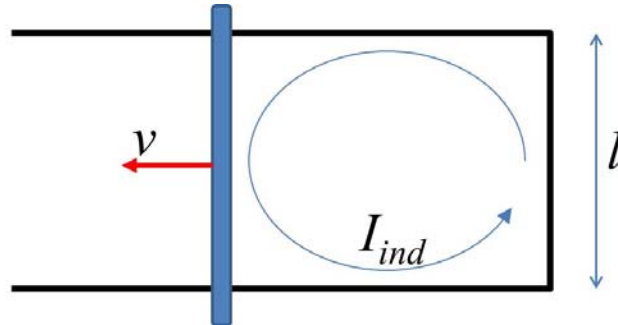

**Formula Sheet:****Electricity and Magnetism****Coulomb's law**

$$F = k \frac{qQ}{r^2}$$

**Electric Field**

$$\vec{E} = \frac{\vec{F}}{q}$$

Field of a point charge

$$E = k \frac{Q}{r^2}$$

Electric field inside a capacitor

$$E = \frac{\eta}{\epsilon_0}$$

Principle of superposition

$$\vec{E}_{net} = \sum_{i=1}^N \vec{E}_i$$

Electric flux

$$\Phi_E = \int \vec{E} \cdot d\vec{A}$$

**Gauss's law**

$$\Phi = \oint \vec{E} \cdot d\vec{A} = \frac{Q_{in}}{\epsilon_0}$$

**Electric potential**

$$V = \frac{U}{q}$$

$$\Delta V = V_f - V_i = - \int_i^f \vec{E} \cdot d\vec{s}$$

For a point charge  $V(r) = \frac{1}{4\pi\epsilon_0} \frac{Q}{r}$ 

For a parallel-plate capacitor

$$V = Es$$

**Potential Energy**

$$U = qV$$

Two point charges

$$U = k \frac{qQ}{r}$$

**Capacitors**

$$C = \frac{Q}{\Delta V}$$

Parallel-plate  $C = \epsilon_0 \frac{A}{d}$ 

Capacitors connected in parallel

$$C_{eq} = C_1 + C_2 + \dots$$

Capacitors connected in series

$$\frac{1}{C_{eq}} = \frac{1}{C_1} + \frac{1}{C_2} + \dots$$

Energy stored in a capacitor  $U = \frac{Q^2}{2C}$ **Ohm's law**

$$V = IR$$

$$I = \frac{dQ}{dt}$$

$$R = \rho \frac{l}{A}$$

$$\sum I_{in} = \sum I_{out}$$

$$\sum \Delta V_i = 0$$

**Power**

$$P = IV$$

**Resistors connected in series**

$$R_{eq} = R_1 + R_2 + R_3 + \dots$$

**Resistors connected in parallel**

$$\frac{1}{R_{eq}} = \frac{1}{R_1} + \frac{1}{R_2} + \frac{1}{R_3} + \dots$$

**The potential difference across a charging capacitor in RC circuit**

$$V(t) = \varepsilon(1 - e^{-t/RC})$$

**“Discharged” RC circuit**

$$Q = Q_0 e^{-t/\tau}; \tau = RC$$

**A magnetic field exerts a force**

$$\vec{dF} = I \vec{dl} \times \vec{B}$$

$$\vec{F} = I \vec{l} \times \vec{B}$$

$$\vec{F} = q \vec{v} \times \vec{B}$$

**The Biot-Savart Law**

$$\vec{B} = \frac{\mu_0 q \vec{v} \times \hat{r}}{4\pi r^2}$$

$$d\vec{B} = \frac{\mu_0 I d\vec{s} \times \hat{r}}{4\pi r^2}$$

**The magnetic field of:**

**A straight line wire**

$$B = \frac{\mu_0 I}{2\pi r}$$

**A solenoid**

$$B = \mu_0 n I$$

**Magnetic flux**

$$\Phi_B = \int \vec{B} \cdot d\vec{A}$$

**Inductance**

$$L = \frac{\Phi_B}{I}$$

$$L = \frac{\mu_0 N^2 A}{l}$$

$$\varepsilon = -L \frac{dI}{dt}$$

**Energy stored in an inductor**

$$U = L \frac{I^2}{2}$$

**Faraday’s Law**

$$\varepsilon = \oint \vec{E} \cdot d\vec{s} = - \frac{d\Phi_B}{dt}$$

**Ampere’s Law**

$$\oint \vec{B} \cdot d\vec{s} = \mu_0 I$$

$$r_{cyc} = \frac{mv}{qB}$$

**Constants**

Charge of an electron

$$e = 1.60 \cdot 10^{-19} C$$

Electron mass  $m = 9.11 \cdot 10^{-31} kg$

Permittivity of free space

$$\varepsilon_0 = 8.85 \cdot 10^{-12} C^2/Nm^2$$

Permeability of free space

$$\mu_0 = 4\pi \cdot 10^{-7} Tm/A$$

$$k = \frac{1}{4\pi\varepsilon_0} = 8.99 \cdot 10^9 Nm^2/C^2$$

**Kinematic eq-ns with const. Acc.:**

$$v(t) = v_{0x} + at$$

$$x(t) = x_0 + v_{0x}t + (1/2) at^2$$

$$v^2 = v_{0x}^2 + 2a(x - x_0)$$

**Centripetal acceleration**  $a_R = v^2/r$

$$L = 2\pi R$$

$$A = \pi R^2$$

$$V = (4/3)\pi R^3$$