

Fourier Transform Spectroscopy

A Dispersive Model

As this year draws to a close, I think some new ideas might be in order for the new year. After reviewing this column's present format with my editor, we have agreed to emphasize more of the "workbench" aspects of the column's title in the coming months, incorporating a forum for troubleshooting questions. Under this new format, I will act as a broker for solutions to spectroscopic problems. When a reader sends in a question, I will find an appropriate "expert" to give some solace to the troubled worker. Both question and answer will be published in a timely manner, but I will also do my darndest to answer the distressed soul in person, so that he or she may proceed with the work at hand.

The approach to the column is not intended to circumvent the service departments of the respective companies, but rather to answer questions regarding techniques, and to address theoretical and other related problems that service representatives may not be familiar with. Write your question on the reader service card or drop me a personal note (through Spectroscopy or directly to my new address at the end of the column).

In the absence of a deluge of mail, however, I am still soliciting contributions and suggestions for topics from readers for this space. If you have suggestions or wish to contribute (not the same as a guest shot on "Miami Vice," I'll grant), please use the reader service card to let me and the editorial staff know of your existence.

Now, down to the business at hand: this month's offering. Professor Ron Williams from Clemson University (Department of Chemistry, Clemson, SC 29634) has written an interesting story about how FT-IR can be explained in dispersive terms. Personally, I didn't think that this was possible, but he has done a fine job. I'm sure you will enjoy this unusual and original tutorial as much as I did.

I wish you all a safe and happy holiday season.

Emil W. Ciurczak
Contributing Editor

In the late 19th century, Albert Michelson invented the interferometer for an experiment that he was conducting to test for the presence of ether in the universe. For this he received the Nobel prize in physics (1). He also realized that the interferometer could be used to make spectral measurements (2), but, unfortunately for him, computational equipment to do the necessary calculations did not become readily available until the latter part of the 20th century. In the interim, less computationally intensive dispersive spectroscopy developed rapidly and grew to dominance. Because of this chronology, all students of interferometry started as dispersive spectroscopists, and interferometry seemed difficult and arcane.

There is nothing inherently difficult about interferometry, now more commonly called Fourier transform spectroscopy. It is simply a different approach to mak-

ing measurements. Rather than producing the spectrum directly, interferometry requires two steps: collecting the signal and mathematically processing it to produce the spectrum. Why bother with this two-step process when the spectrum is readily available dispersively? There are several significant advantages offered by the interferometer, that, in certain applications, offer significant improvements in the collected spectra.

In this column I will present a model of interferometry using equipment familiar to dispersive spectroscopists: prisms, choppers, amplifiers, and the like. This "working model" of the interferometer is presented as a transitional step between interferometry and dispersive spectroscopy. Although crude, it explains many of the advantages and disadvantages of Fourier transform spectroscopy.

THE INTERFEROMETER

The interferometer, as illustrated in Figure 1, is a mechanically simple device consisting of only three pieces: two mirrors and a beam splitter. This latter device, the most mysterious part, is simply a "half-mirror"; that is, it reflects half the light that strikes it and transmits the other half. (Actually, no beam splitter operates in exactly this way. A portion of the light is also absorbed by the beam splitter — it is more common for 40% of the light to be reflected, 40% transmitted, and 20% absorbed.)

Light that enters from the source strikes the beam splitter and is divided into two beams that are sent down two separate "arms" of the interferometer to the mirrors. All that happens at the mirrors, of course, is that the light is reflected back to the beam splitter where the same transmission-reflection occurs

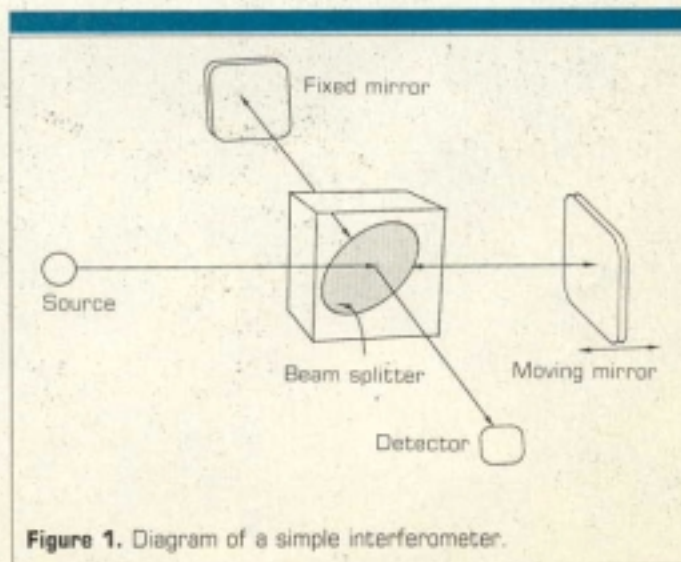

Figure 1. Diagram of a simple interferometer.

again. The net result is that half of the light from the source returns to the source, and the other half goes to the detector.

Things are quite simple from the detector's point of view. It looks at two images of the source simultaneously, one from each mirror. The signal recorded by the detector is the apparent brightness of the source measured as one of the mirrors moves. This intensity will increase and decrease as the moving mirror sweeps out its path, generating what is called an interference pattern — hence the name interferometer. (The size of this signal is greatest at the point where both mirrors are the same distance from the beam splitter. This is referred to as the zero path difference, or ZPD.)

In most explanations, the interference of the photons is introduced at this point to explain why the intensity varies with mirror movement (3). However, the operation of the interferometer can also be explained using more familiar concepts.

A DISPERSIVE MODEL

The essence of interferometry is expressed in Figure 2. For simplicity, we assume a source that emits only two wavelengths hav-

ing the intensities shown in (b). These impinge on a prism, something very familiar to dispersive spectroscopists, and each is bent at a different angle and then sent through two separate choppers that are operating at different frequencies. The blue light has been bent more by the prism than the red, and its chopper operates at a correspondingly higher rotation rate than that of the red. The detector sees both of these signals simultaneously because the second prism is adjusted to make the light collinear again. (Note the similarity to the roles of the beam splitter: one prism divides the light, and the second recombines it.)

The signal observed by the detector in this example is the sum of the two square waves caused by the rotation of the choppers, shown in Figure 2b. The blue light is approximately twice as intense as the red light. In this example, its square wave occurs at a frequency of 6 Hz while the frequency of the red light is at 2 Hz. (In the jargon of Fourier transform spectroscopy, we say that the source has been modulated by the interferometer.)

The major advantage of interferometry over dispersive spectroscopy is also illustrated in this fig-

ure. The sum of the two signals is recorded by a single detector. This is the origin of what is known as the multiplex advantage. The detector records both signals simultaneously; thus, detector noises are spread over both signals equally — that is, each square wave ends up with one-half of the total detector noise. A dispersive spectroscopist would leave out the second prism and record each wavelength separately. If we spend one second recording the signal shown in Figure 2, the interferometer will have recorded one second's worth of noise to be split evenly between the two signals. A dispersive measurement would require that we measure first the blue light for one second and then the red. Each signal would get a full measure of one second's worth of detector noise. Notice that the more wavelengths of light that are present in the spectrum, the bigger this effect.

In summary, each wavelength of light incident on the interferometer is converted to a chopped frequency that is proportional to its energy; that is, shorter-wavelength light shows up at higher frequencies. The signal is monitored as a function of time, and this is why the interferogram is referred to as a time-domain signal. (All frequencies are measured with a time abscissa.)

EXTRACTING THE SPECTRUM

But how do we get the spectrum from this information? The frequency is directly related to the wavelength, as we have seen; however, we need some method for quantitation. One approach is to listen to the signal (because your ears are frequency processors). A monochromatic signal would sound like a single note from a piano. As more frequencies are added to the spectrum, the sound would become more complex, forming complicated chords.

This is clearly unsatisfactory

for analytical spectroscopy. In order to extract useful information we must have the spectrum — that is, intensity as a function of wavelength (or some related parameter such as wavenumber). The first approach taken by a dispersive spectroscopist would be to use a bank of tuned amplifiers to produce the spectrum. We would have to supply one amplifier tuned to the frequency of each chopper. The output of the amplifier (peak-to-peak voltage) would correspond to the intensity of the spectrum at that frequency, and because each frequency is proportional to the wavelength of the light producing it, we could plot these numbers and produce the spectrum.

This approach, however, would be far too expensive — and there is a better way. By allowing a computer to store the signal from the detector we can use a mathematical approach to extract the amounts of each frequency. The counterpart of the tuned-amplifier approach uses digital filtering to process the data over and over sequentially, extracting each piece of frequency information. This also is extremely inefficient. The most efficient approach discovered so far is to use a mathematical technique known as the Fourier transform to extract this information. In essence, it performs the same function as the bank of tuned amplifiers: it extracts the frequency identities and intensities in parallel.

PHASE CORRECTION

Let's return to our dispersive model in Figure 3. An even more sensitive processing scheme would be to replace the tuned amplifiers with lock-in amplifiers. In this case each amplifier would process the signal from the detector using a reference signal generated from its chopper, which would allow discrimination using frequency and phase.

The role of phase in our disper-

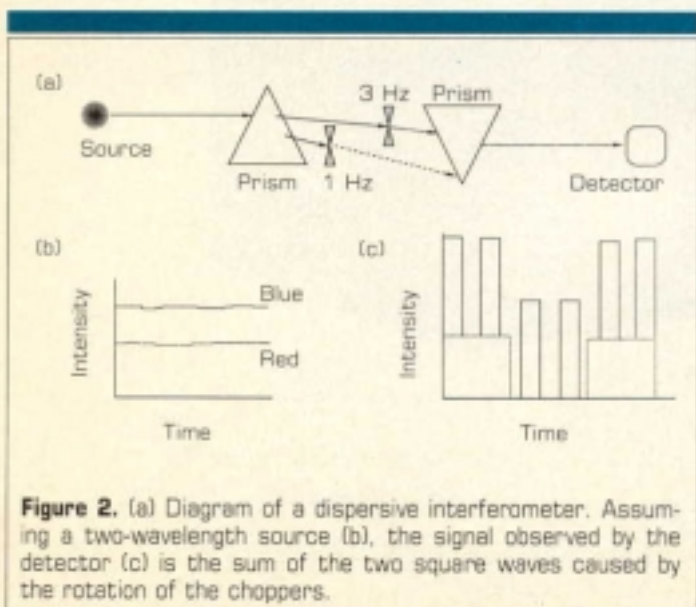

Figure 2. (a) Diagram of a dispersive interferometer. Assuming a two-wavelength source (b), the signal observed by the detector (c) is the sum of the two square waves caused by the rotation of the choppers.

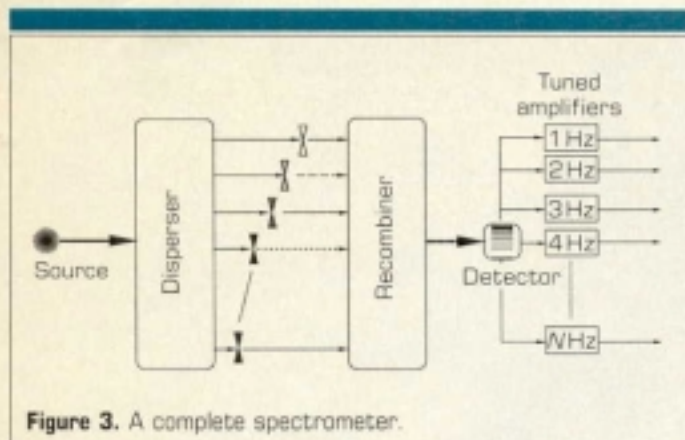

Figure 3. A complete spectrometer.

sive interferometer comes into play because each chopper may not have started spinning at the same time. In interferometry this can be caused by imperfections in the beam splitter and electronics, or it can arise from the sample. The effect that this phase shift (that is, phase error) has on the recorded data is illustrated in Figure 4, which shows what happens when two frequencies are recorded slightly out of phase. If both choppers in our example had started at the same time, the frequencies would be in phase and the sum seen by the detector would have symmetry, as shown in (a). However, if the two choppers had started at slightly different times, the signals would be slightly out of phase, as shown in (b). The summation recorded by the detector loses its symmetry as a result. This loss of symmetry is the indication that phase errors are present in the interferogram.

In the tuned-amplifier example, this error would have no measurable effect on the resulting spectrum. But because the Fourier transform processes all of the frequencies as a group, the slight shift shows up as "derivative-like" features in the spectrum (4). In order to avoid this, several mathematical procedures, termed *phase correction*, are used to fix these slight phase shifts either before or after the transformation.

FREE SPECTRAL RANGE AND ALIASING

One problem that will result from our model is that if we have a broadband source, literally millions of different optical

ONE of the most valuable advantages regarding interferometry is its ability to provide extremely high resolution in relatively compact instrumentation.

wavelengths will be produced. How can we produce enough choppers to encode each at a different frequency? The answer is that we can't. The number of choppers (unique frequencies) available from the interferometer is controlled by the total distance that we allow the mirror to travel. If it travels 2 cm, we will have twice as many available choppers than if it only travels 1 cm. In either case, all of the wavelengths in the spectrum will be distributed equally across the available frequencies. In other words, the resolution (total num-

ber of frequencies produced in the spectrum) of the interferometers is controlled by the distance that the mirror is driven. In theory, we can continue increasing the number of choppers ad infinitum to achieve any resolution. In practice, one of the most valuable advantages of interferometry is its ability to provide extremely high resolution (5) in relatively compact instrumentation.

We still have one subtle point left to make about this frequency encoding. The frequencies produced by the interferometer begin at 0 Hz and increase to some maximum value. How do we know what this value is? It would seem that as we increase the distance that the mirror travels we would increase this upper limit, but this is not true. The choppers will run from 0 Hz up to a maximum that is determined by the shortest wavelength present in the spectrum regardless of mirror travel. The interferometer is capable of producing a unique frequency for every frequency in the spectrum, no matter how short the wavelengths are. However, this signal must be digitized by a computer before it can be processed. This introduces a general data-acquisition problem called *aliasing* and its related spectroscopic concept of free spectral range (6).

Aliasing, as the name implies, describes the process in which a frequency shows up in the digitized interferogram with the wrong identity. The frequency at which aliasing begins is the upper limit of the free spectral range, and any wavelengths of light producing frequencies above this limit will "fold" back into the spectrum like an accordion. This process is controlled by the rate at which the computer records data from the interferometer and has nothing to do with how far the mirror travels. (In fact, the exact frequency of the chopper in our example is controlled by the speed at which the mirror is driven back and

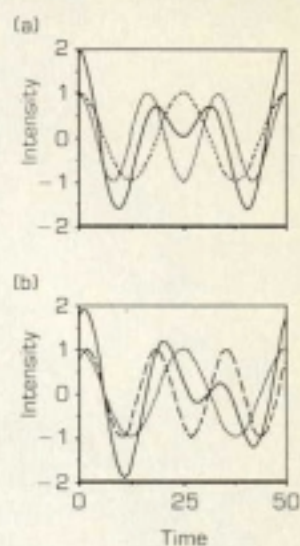

Figure 4. Effect of phase errors on an interferogram: (a) in phase — both choppers start at the same time, and (b) out of phase — the choppers start at different times.

forth. If the mirror velocity is doubled, then the frequencies of all the choppers are also doubled. This is why it is so important that the mirror be driven at a constant velocity in an interferometer: All velocity errors show up as errors in the spectrum.)

If the computer reads data in at a rate of 1000 Hz, then the highest frequency that will be recorded properly is 500 Hz. (This is known as Nyquist's theorem.) A frequency of 600 Hz will not be recorded properly and, in fact, will show up in the digitized spectrum as 400 Hz; that is, it will alias back on the spectrum by an amount equal to how far it is located above the Nyquist frequency. The free spectral range of the interferometer in this case would be 500 Hz. All frequencies above this value will be recorded with the wrong identities, unless they are removed by electronic filtering prior to digitization. Aliasing is not necessarily bad because there is a