



## OSHA Technical Manual

[TABLE OF CONTENTS](#)

[NEXT CHAPTER](#)

### SECTION II: CHAPTER 1 [New additions and extensively revised]

#### PERSONAL SAMPLING FOR AIR CONTAMINANTS

##### Contents:

- I. [Introduction](#)
- II. [General Sampling Procedures](#)
- III. [Sampling Media](#)
- IV. [Special Sampling Procedures](#)
- V. [Equipment Preparation and Calibration](#)
- VI. [Filter Weighing](#)
- VII. [Bibliography](#)

##### [Appendix II:1-1. Detector Tubes and Pumps](#)

##### [Appendix II:1-2. Electronic Flow Calibrators](#)

##### [Appendix II:1-3. Manual Buret Bubble Meter Technique](#)

##### [Appendix II:1-4. Shelf Life of Sampling Media Provided by SLTC](#)

##### [Appendix II:1-5. Sampling for Special Analyses](#)

##### [Appendix II:1-6. Sampling and Analytical Errors \(SAE's\)](#)

##### [Appendix II:1-7. List of Substances for Autoweighing Submission](#)

#### 1. INTRODUCTION.

1. Effective and efficient sampling strategies require planning and foresight to ensure the most productive and thorough evaluation of air contaminants in the workplace. Air sampling should be conducted when necessary and laboratory resources should be used wisely to avoid delays in reporting results of necessary sampling. When possible, evaluate the potential for employee overexposure by observing work practices and screening samples before conducting any partial or full-shift air sampling.
2. Screening with portable monitors, gravimetric sampling, or detector tubes should be used to evaluate the following:
  1. Exposures to substances with exceptionally high permissible exposure limits (PEL's) in relatively dust-free atmospheres, e.g., ferric oxide and aluminum oxide;
  2. Intermittent processes involving substances without short-term exposure limits (STEL's);
  3. Engineering controls, work practices, or isolation of process; and the need for CSHO protection;
  4. Substances that have Ceiling exposure limits. (There are validated direct-reading sampling devices available specifically for these substances.)
3. Take a sufficient number of samples to obtain a representative estimate of exposure. Contaminant concentrations vary seasonally, with weather, with production levels, and in a single location or job class. The number of samples taken depends on the error of measurement and differences in results. Consult the *NIOSH Occupational Exposure Sampling Strategy Manual* for further information.
4. If the employer has conducted air sampling and monitoring in the past, review the records.
5. Bulk samples are often required to assist the Salt Lake Technical Center (SLTC) in the proper analysis of field samples. (See Section II, Chapter 4, Sample Shipping and Handling.) Some contaminants in these categories are:

- silica
- Portland cement
- asbestos
- mineral oil and oil mist
- chlorodiphenyl
- hydrogenated terphenyls
- chlorinated camphene
- fugitive grain dust
- explosibility testing

6. Bulk samples can also be taken and analyzed to support any Hazard Communication inspections (i.e., Material Safety Data Sheet determinations).

2. **GENERAL SAMPLING PROCEDURES. NOTE:** Radio frequency electromagnetic fields can interfere with the proper operation of industrial hygiene instruments. This interference is called electromagnetic susceptibility (EMS). Determine if there is a potential for such interference. Likely sources of radio frequency interference are walkie-talkies, vehicles equipped with mobile radio transmitters, RF heat sealers, etc. If there is a potential for such interference, select sampling instruments that are properly rated for EMS to avoid faulty data or malfunction.

1. **SAMPLING PREPARATIONS.** Screen the sampling area with detector tubes, if appropriate. Determine the appropriate sampling technique [see the [Chemical Sampling Information](#) section of the [Technical Information link](#) found via the Web (<http://www.osha.gov/SLTC/index.html>) or the Technical Information section of [OSHA CD-ROM](#)]. Prepare and calibrate the equipment and prepare the filter media (if sample weights are necessary, see Section VI., Filter weighing, below.). Figure II:1-1a shows the appropriate assembly for the three piece sampling cassette used to collect specific particulates. Other sampling media usage and preparation can be found within this chapter, via Technical Links ([Chemical Sampling Information](#) or specific [analytical methods](#)), or the OSHA CD.

2. **SELECT THE EMPLOYEE** to be sampled and discuss the purpose of the sampling. Inform the employee when and where the equipment will be removed. Stress the importance of not removing or tampering with the sampling equipment. Instruct the employee to notify the supervisor or the CSHO if the sampler requires temporary removal.

### 3. STARTING SAMPLING.

1. Place the sampling equipment on the employee so that it does not interfere with work performance. Attach the collection device (filter cassette, charcoal tube, etc.) to the shirt collar or as close as practical to the nose and mouth of the employee, i.e., in a hemisphere forward of the shoulders with a radius of approximately six to nine inches. The inlet should always be in a downward vertical position to avoid gross contamination. Position the excess tubing so that it does not interfere with the work of the employee.

2. Turn on the pump and record the starting time.

3. Observe the pump operation for a short time after starting to make sure it is operating correctly.

4. Record the information required by the Air Sampling Data Form (OSHA 91A).

### 4. MONITORING.

1. *Check pump every two hours.* More frequent checks may be necessary when heavy filter loading is possible. Ensure that the sampler is still assembled properly and that the hose has not become pinched or detached from the cassette or the pump. For filters, observe for symmetrical deposition of particulate on the filter, unexpected large particles, or other evidence of sample tampering with the sample or pump. Record the flow rate and any relevant observations.

2. Periodically monitor the employee throughout the workday to ensure that sample integrity is maintained and cyclical activities and work practices are identified. Turn off or remove sampling pumps immediately prior to an employee leaving a potentially contaminated area (such as when he/she goes to lunch or on a break in a clean area). If these areas also appear contaminated and are considered part of the workplace, continue sampling and assess the need for surface contamination measurements (see also Section II, Chapter 2, Sampling for Surface Contamination).

FIGURE II:1-1a. EXPLODED VIEW OF THREE-PIECE CASSETTE SHOWS PLACEMENT OF BACK-UP PAD.

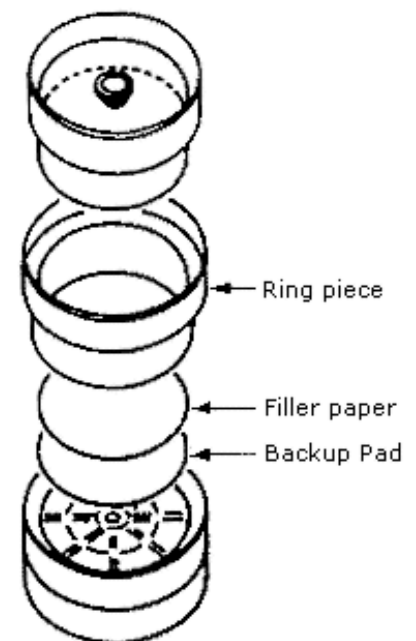

3. Take photographs (as appropriate) and detailed notes concerning visible airborne contaminants, work practices, potential interferences, movements, and other conditions to assist in determining appropriate engineering controls.
4. Prepare blank(s) during the sample period for each type of sample collected. (Also see Section II, Chapter 4, Sample Shipping and Handling.) One blank will suffice for up to 20 samples for any given analysis/sampling period except asbestos, which requires a minimum of two field blanks. The blanks should be opened but not used to take samples (charcoal tubes, filters etc.). They should be handled in the same manner as any sampling media used in sampling air contaminants, with the exception that no air is drawn through them.

### 5. FINAL PROCEDURES.

1. Before removing the pump at the end of the sample period, if there is a pump rotameter, check the flow rate to ensure that the rotameter ball is still at the calibrated mark. If the ball is no longer at the mark, record the pump rotameter reading.
2. Turn off the pump and record the ending time.
3. Remove the collection device from the pump and seal it with an OSHA-21 form as soon as possible. The seal should be attached across sample inlet and outlet so that tampering is not possible. (See Figures II: 1-1b and II: 1-1c.)

**FIGURE II:1-1b. IMPROPERLY SEALED CASSETTE ALLOWS ACCESS TO INLET AND OUTLET AFTER SAMPLE HAS BEEN TAKEN.**

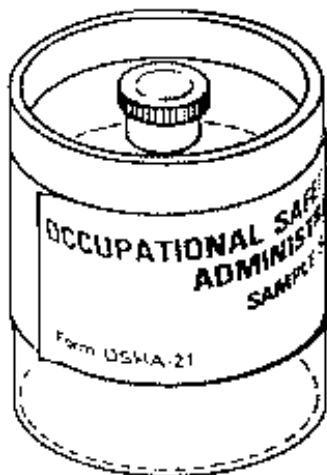

**FIGURE II:1-1c. PROPERLY SEALED CASSETTE WITH OSHA-21 FORM COVERING INLET AND OUTLET PORTS PROVIDES SECURITY.**

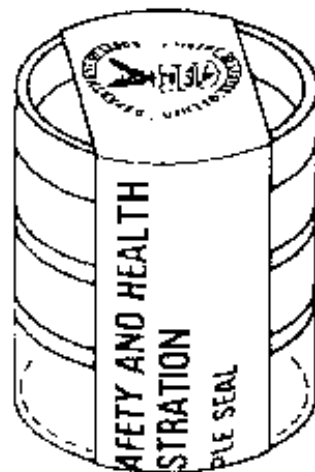

4. Prepare the samples for mailing to the Salt Lake Technical Center (SLTC) for analysis. (Also see Section II, Chapter 4.) Mail bulk samples and air samples separately to avoid cross-contamination. If any sample materials could be considered hazardous, always consult and follow appropriate shipping regulations to assure safe handling during shipment. Pack the samples securely to avoid any rattle or shock damage (do not use expanded polystyrene packing). Use bubble sheeting as packing. Put identifying paperwork in every package. Do not send samples in plastic bags or in envelopes. Use OSHA Form 91A. *Print legibly on all forms.*
5. Recalibrate pumps after each day of sampling (before charging). Take proper care of battery packs (see Section II, Chapter 3 - III. Batteries).
6. When calibrating conditions are significantly different from sampling site conditions such as large temperature and pressure differences, call the Salt Lake City Technical Center.

### 3. SAMPLING MEDIA.

1. **DETECTOR TUBES.** Each pump should be leak-tested before use. Calibrate the detector tube pump for proper volume at least quarterly or after 100 tubes (See [Appendix II:1-1](#)).
2. **TOTAL DUST AND METAL FUME - AEROSOL SAMPLERS.**
  1. Collect total dust on a preweighed, low-ash polyvinyl chloride (PVC) filter (See Section VI, Filter Weighing below) at a flow rate of about 2 liters per minute (L/min), depending on the rate required to prevent overloading.
  2. Collect metal fumes on a 0.8-micron mixed cellulose ester (MCE) filter at a flow rate of approximately 1.5 L/min, not to exceed 2.0 L/min. When the gravimetric weight needs to be determined for welding fumes, use the

sampling device described in Section VI, Filter Weighing, for gravimetric determinations.

3. Take care to avoid overloading the filter, as evidenced by any loose particulate.
4. Calibrate personal sampling pumps before and after each day of sampling, using a bubble meter method (electronic or mechanical) or the precision rotameter method (that has been calibrated against a bubble meter), as described in Section V, part E-2, below. Assure the calibration equipment (bubble meter, etc.) is within its prescribed calibration interval, and record the serial number of the calibration bubble meter (or rotameter) in your data.

**NOTE:** Using precision rotameters for pump calibration should be avoided if at all possible. Tests have indicated significant measurement errors due to pump pulsations.

5. PVC filters used for gravimetric analysis need to be pre- and post-weighed. See Section VI, Filter Weighing for further details.
3. **RESPIRABLE DUST SAMPLERS.** Collect respirable dust using a clean cyclone equipped with a preweighed low-ash polyvinyl chloride filter at a flow rate of 1.5 to 2.0 L/min. (See Figure II: 1-2.). Pre-weighed filters are available from SLTC or CTC (see Section VI, Filter Weighing, below, for further information). Collect silica only as a respirable dust, and, if possible, submit a bulk sample also to SLTC.

1. **Calibration Procedures**

- a. Perform the calibration at the pressure and temperature where the sampling is to be conducted.
- b. For respirable dust sampling using a cyclone, or for total dust sampling using an open-face filter cassette, set up the calibration apparatus as shown in Figure II: 1-9.
- c. Place the open-face filter cassette, or cyclone assembly in a 1-liter jar. The jar is provided with a special cover.
- d. Connect the tubing from the electronic bubble meter to the inlet of the jar.
- e. Connect the tubing from the outlet of the cyclone holder assembly or from the filter cassette to the outlet of the jar and then to the sampling pump.
- f. Calibrate the pump with a light and heavy load, both pre- and post-sampling. All readings must be within five percent of each other.

2. **Alternative Calibration Method - "Jarless Cyclone Calibration."**

The following "Jarless Cyclone Calibration" is an alternative method to calibrating the cyclone with a 1-liter jar. This method will be included in the NIOSH Manual of Analytical Methods (NMAM), Fourth Edition.

- a. Connect the air sampling pump to a TEE fitting, a pressure gauge (0" to 50" H<sub>2</sub>O vacuum full scale) or water manometer, a light load (typically a 5- $\mu$ m, 37mm filter), and a calibrated electronic bubble meter (or standard bubble tube).

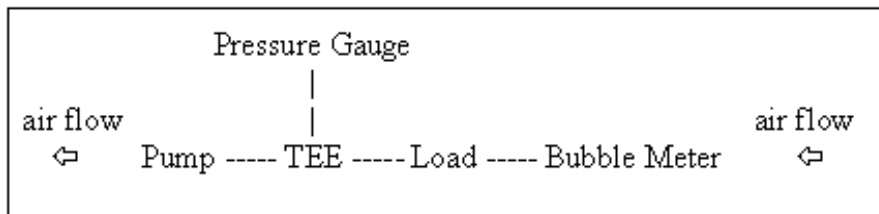

- b. Adjust the air sampling pump to 1.7 L/min as indicated on the bubble meter, and adjust the loading, if necessary, to produce a 2" to 5" H<sub>2</sub>O indication on the pressure (vacuum) gauge. c. Increase the loading (typically five to six 0.8- $\mu$ m, 37-mm filters) until the pressure (vacuum) gauge indicates between 25" and 35" H<sub>2</sub>O, and check the flow rate again. The flow rate should remain at 1.7 L/min  $\pm$  5%. d. Finally, replace the load and bubble meter with the cyclone having a clean filter installed, and verify that the loading caused by the cyclone assembly is between 2" and 5" H<sub>2</sub>O.

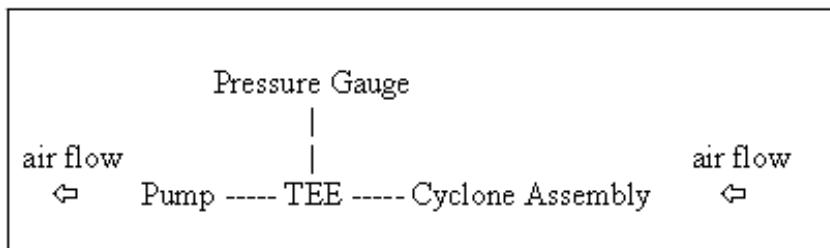

- e. This calibration method actually performs a dynamic test of the pump under load.

3. **Cyclone Cleaning.**

- a. Unscrew the grit pot from the cyclone. Empty the grit pot by turning it upside down and tapping it gently on a solid surface.
- b. Clean the cyclone thoroughly and gently after each use in warm soapy water or, preferably, wash in an ultrasonic bath. Rinse thoroughly in clean water, shake off excess water, and set aside to dry before reassembly. *Never insert anything into the cyclone during cleaning.* See Figure II: 1-2.

**FIGURE II:1-2. CYCLONE ASSEMBLY.**

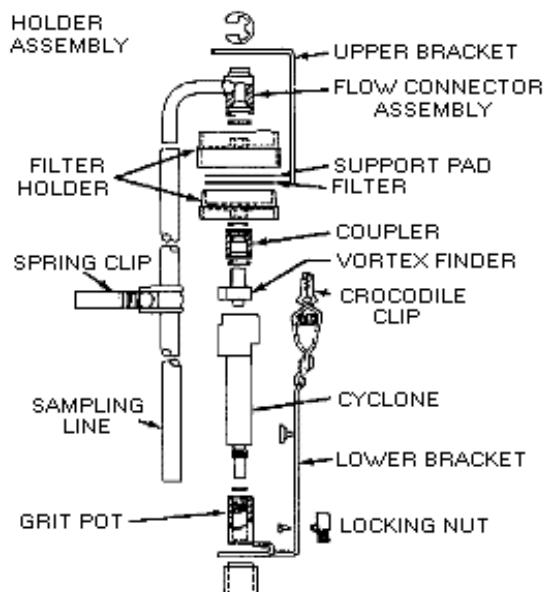

- c. Inspect the cyclone parts for signs of wear or damage such as scoring, rifling, or a loose coupler. Replace the units or parts if they appear damaged.
- d. Leak test the cyclone before use unless it has been leak tested within the past month. A cyclone leak Test Kit and Cyclone Leak Test Procedure are provided in each office for this purpose.
- e. Detailed instructions on leak testing are available from the Directorate of Technical Support, Cincinnati Technical Center (CTC) and are available through Technical Links on our Web Page for [silica](#).

#### 4. SOLID SORBENT TUBES.

1. Organic vapors and gases may be collected on activated charcoal, silica gel, or other adsorption tubes using low-flow pumps (see Figure II:1-3).

**FIGURE II:1-3. THE CHARCOAL OR "C"-TUBE WITH GLASS-SEALED END AND NIOSH-APPROVED CAPS BEFORE SAMPLING.**

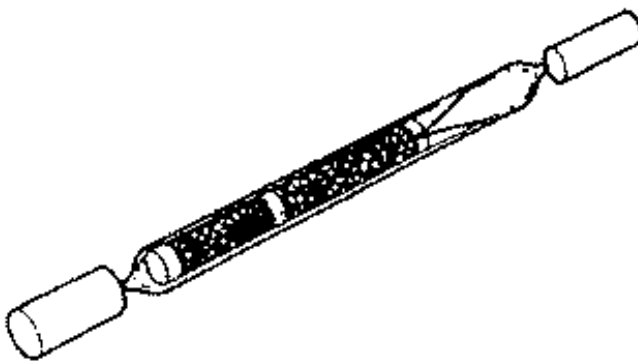

2. Immediately before sampling, break off the ends of the flame-sealed tube so as to provide an opening approximately half the internal diameter of the tube. Wear eye protection when breaking ends. Use tube holders, if available, to minimize the hazards of broken glass. Do not use the charging inlet or the exhaust outlet of the pump to break the ends of the tubes.
3. Use the smaller section of the tube as a back-up and position it near the sampling pump. The tube shall be held or attached in an approximately vertical position with the inlet either up or down during sampling.
4. Draw the air to be sampled directly into the inlet of the tube. This air is not to be passed through any hose or tubing before entering the tube.

5. Cap the tube with the supplied plastic caps immediately after sampling and seal with an OSHA-21 form as soon as possible. (See Figures II:1-4a and b.) Do not ship tubes with bulk material.

**FIGURE II:1-4a. CORRECTLY SEALED C-TUBE. SAMPLE IS COMPLETELY ENCLOSED IN THE SEAL, AND NO TAMPERING IS POSSIBLE.**



**FIGURE II:1-4b. INCORRECTLY SEALED C-TUBE. END CAPS CAN BE REMOVED AND SAMPLE INTEGRITY JEOPARDIZED WITHOUT DISTURBING THE SEAL.**

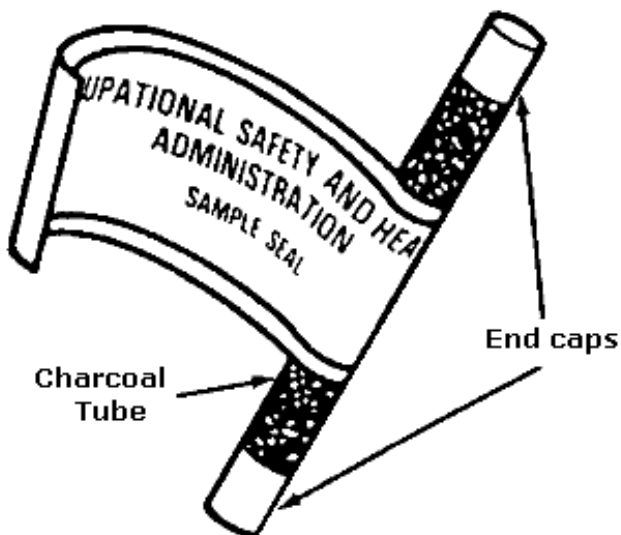

6. Tubes may be furnished by SLTC with either caps or flame-sealed glass ends. If using the capped version, simply uncap during the sampling period and recap at the end of the sampling period.
7. For organic vapors and gases, low-flow pumps are required. Refer to the [Chemical Sampling Information](#) for flow rates recommended for specific chemicals.
8. With sorbent tubes, flow rates may have to be lowered or smaller air volumes (half the maximum) used when there is high humidity (above 90%) in the sampling area or relatively high concentrations of other organic vapors are present.
9. Set up the calibration apparatus as shown in Figure II:1-8 replacing the cassette with the solid sorbent tube to be used in the sampling (e.g., charcoal, silica gel, etc.). If a sampling protocol requires the use of two charcoal tubes, the calibration train must include two charcoal tubes. The air flow must be in the direction of the arrow on the tube. Calibrate the pump.

## 5. MIDGET IMPINGERS AND BUBBLERS.

### 1. Method.

- a. Take care in preparing bubblers and impingers to see that frits or tips are not damaged and that joints can be securely tightened.

b. Rinse the impinger or bubbler, Figure II:1-5, with the appropriate reagent (see Technical Links, [Chemical Sampling Information](#) via the Web or the OSHA-CD and [Appendix II:1-4](#)). Then add the specified amount of this reagent to the bubbler or impinger flask either in the office or at the sampling location. If flasks containing the reagent are transported, caps must be placed on the bubbler or impinger stem and side arm.

c. To prevent overflow, do not add over 10 ml of liquid to the midget impingers or bubblers.

d. Collect contaminants in an impinger or bubbler at a maximum flow rate of 1.0 L/min. Because bubblers tend to offer better collection efficiency than impingers, they are the preferred method over impingers for gas and vapor collection. Impingers are used, if absolutely necessary, for particle counting. Contact the SLTC prior to collecting any samples for particle (dust) counting.

e. The impinger or bubbler may either be hand-held by the industrial hygienist or attached to the employee's clothing using an impinger or bubbler holster. In either case, it is very important that the impinger or bubbler does not tilt and cause the reagent to flow down the side arm to the hose and into the pump. **NOTE:** Attach a trap in line to the pump, if possible.

f. In some instances, it will be necessary to add additional reagent during the sampling period to prevent the amount of reagent from dropping below one half of the original amount.

g. After sampling, remove the glass stopper and stem from the impinger or bubbler flask.

h. Rinse the absorbing solution adhering to the outside and inside of the stem directly into the impinger or bubbler flask with a small amount (1-2 ml) of the sampling reagent. Pour the contents of the flask into a 20-ml glass bottle (preferably a scintillation vial with inert caps and liners). Avoid using metal cap liners or other materials that may react with the samples. Teflon cap liners with polypropylene caps are normally inert to most materials. Rinse the flask with a small amount (1-2 ml) of the reagent and pour the rinse solution into the bottle or vial. Tape the cap shut by wrapping the tape in the direction of cap closure to prevent it from coming loose due to vibration. If electrical tape is used, do not stretch tape since it will contract and loosen cap.

**FIGURE II:1-5. A TYPICAL GLASS BUBBLER**

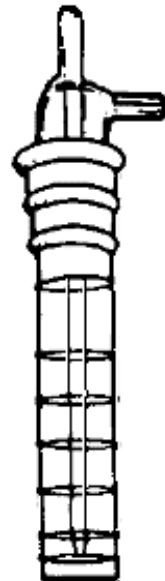

## 2. Calibration.

a. Set up the calibration apparatus as shown in Figure II:1-8 and replace the cassette with the impinger or bubbler filled with the amount of liquid reagent specified in the sampling method. (Refer to [Chemical Sampling Information](#) via Technical Links or the OSHA CD.)

b. Connect the tubing from the electronic bubble meter to the inlet of the impinger or bubbler.

c. Connect the outlet of the impinger or bubbler to the tubing to the pump.

d. Calibrate the pump up to a maximum flow rate of 1.0 L/min.

F. **VAPOR BADGES.** Passive-diffusion sorbent badges (also known as monitors), Figure II:1-6, are useful for screening and compliance monitoring for certain chemical exposures, especially vapors and gases. The major advantage is that no sampling pump is needed to take the samples. Some badges have been validated for use in compliance. Badges are available from the SLTC to detect mercury, nitrous oxide, ethylene oxide, formaldehyde, and other organic substances. Specific sampling procedures for each type of badge are also supplied with the monitors. Interfering substances should be noted during sampling and recorded. Contact the SLTC for further information regarding badge availability and use.

**FIGURE II:1-6. VAPOR BADGE WITH CLOTHING CLIP.**



## 4. SPECIAL SAMPLING PROCEDURES

### 1. ASBESTOS.

1. Collect asbestos on a special 0.8 micrometer pore size, 25-mm diameter mixed cellulose ester filter with a back-up pad. Use a fully conductive cassette with conductive extension cowl, Figure II:1-7.
2. Sample open face (the filter/cowl is open to the sampling environment; the extension cowl is in place but the cowl end piece is removed from the extension) in the worker's breathing zone.
3. Ensure that the bottom joint (between the extension and the conical black piece) of the cassette is sealed tightly with a shrink band or electrical tape. Point the open face of the cassette down to minimize contamination.
4. Use a flow rate in the range of 0.5 to 5 L/min. One liter per minute is suggested for general sampling. Office environments allow flow rates of up to 5 L/min. Calibrate pump before and after sampling. Calibration may be done either as in Figure II:1-8 or Figure II:1-9. Do not use nylon or stainless-steel adaptors if in-line (Figure II:1-8) calibration is done.

**FIGURE II:7. A STANDARD ASBESTOS CASSETTE (25 mm) SEALED PROPERLY WITH AN OSHA 21 FORM**

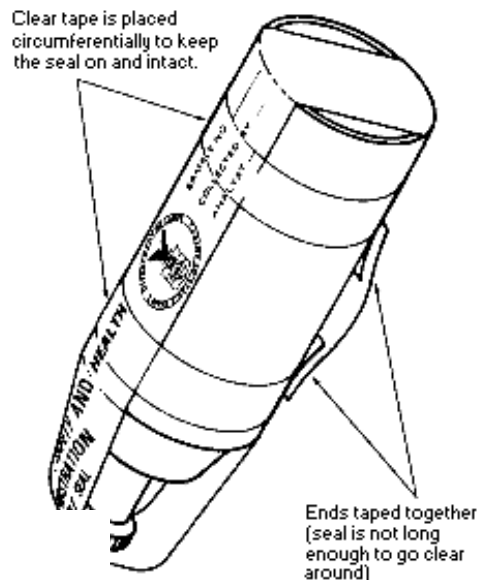

**FIGURE II:1-8. FOR CALIBRATION, THE CASSETTE IS ATTACHED TO AN ELECTRONIC BUBBLE METER.**

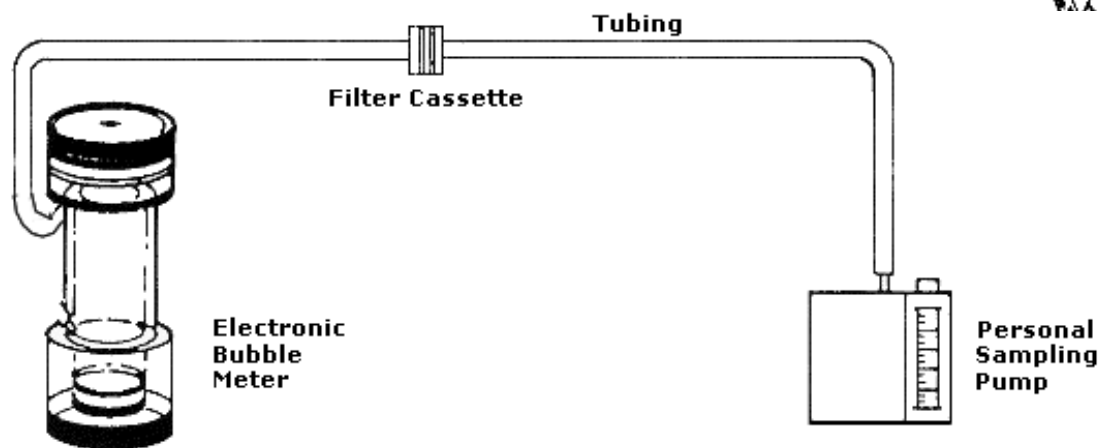

**FIGURE II:1-9. THE CYCLONE IS CALIBRATED BY PLACING THE CYCLONE IN A 1 LITER VESSEL ATTACHED TO AN ELECTRONIC BUBBLE METER.**

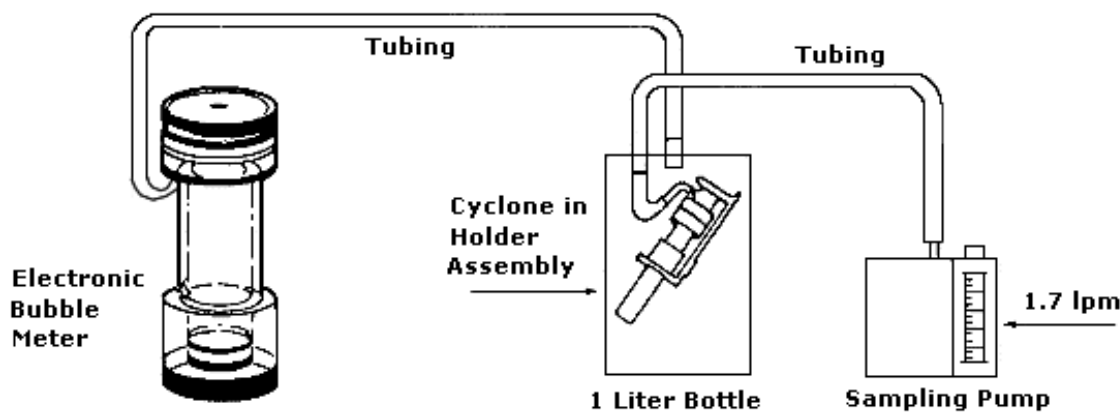

5. Sample for as long a time as possible without overloading (obscuring) the filter.
6. Instruct the employee to avoid knocking the cassette and to avoid using a compressed-air source that might dislodge the sample while sampling.
7. Submit 10% blanks, with a minimum of two blanks in all cases.



8. Where possible, collect and submit to the SLTC a bulk sample of the material suspected to be in the air.
9. Mail bulk sample and air samples separately to avoid cross-contamination. Pack the samples securely to avoid any rattle or shock damage (do not use expanded polystyrene packing). Use bubble sheeting as packing. Put identifying paperwork in every package. Do not send samples in plastic bags or envelopes. Use OSHA Form 91A. *Print legibly on all forms.*
10. For exceptional sampling conditions or high flow rates, contact the SLTC. More detailed instructions can be obtained from SLTC.

#### 5. SAMPLING FOR WELDING FUMES.

1. When sampling for welding fumes, the filter cassette must be placed inside the welding helmet to obtain an accurate measurement of the employee's exposure.

**NOTE:** The policy of placing the inlet of the sampling device inside of personal protective equipment for the face or eyes applies only to welding hoods. The inlet of the sampling device shall be placed **outside** other face or eye personal protective equipment, such as face shields for projectiles or chemical splashes.

2. Welding fume samples are normally taken using 37-mm filters and cassettes; however, if these cassettes will not fit inside the helmet, 25-mm filters and cassettes can be used. Care must be taken not to overload the 25-mm cassette when sampling.
3. The Assistant Regional Administrator for Technical Support should be consulted in the case of technical difficulties.

#### 6. EQUIPMENT PREPARATION AND CALIBRATION.

1. **ALKALINE BATTERIES.** Replace alkaline batteries as needed. Keep fresh replacement batteries with the equipment.
2. **RECHARGEABLE NI-CAD BATTERIES.** Check the rechargeable Ni-Cad batteries in older pumps under load (e.g., turn pump on and check voltage at charging jack) before use. (See Section II, Chapter 3, Part III. - Batteries)
3. **TIME OF CALIBRATION.** Calibrate personal sampling pumps before and after each day of sampling, using either the electronic bubble-meter method or the precision-rotameter method calibrated against a bubble meter. Make sure that the calibration equipment (bubble meter, etc.) is within its prescribed calibration interval and record the serial number of the calibration instrument in your data.
4. **ELECTRONIC FLOW CALIBRATORS.** These units are high-accuracy electronic bubble flow meters that provide instantaneous air-flow readings and cumulative averaging of multiple samples. These calibrators measure the flow rate of gases and present the results as volume per unit of time and should be used to calibrate all air-sampling pumps. [Appendix II: 1-1](#) provides more information on this piece of equipment.
5. **CALIBRATION.** When a sampling train requires an unusual combination of sampling media (e.g., glass fiber filter preceding impinger), the same media and devices should be in line during calibration.

##### 1. Electronic Bubble Meter Method.

- a. Allow the pump to run five minutes prior to voltage check and calibration.
- b. Assemble the cassette filter holder, using the appropriate filter for the sampling method. Compress cassette by using a mechanical press or other means of applying pressure. Use shrink tape around cassette to cover joints and prevent leakage. If a cassette adaptor is used, care should be taken to ensure that it does not come in contact with the back-up pad. **NOTE:** When calibrating with a bubble meter, cassette adaptors can cause moderate to severe pressure drop at high flow rates in the sampling train and affect the calibration result. If adaptors are used for sampling, they should also be used when calibrating. **CAUTION:** Nylon adapters can restrict air flow due to plugging. Stainless-steel adapters are preferred.
- c. Connect the collection device, tubing, pump, and calibration apparatus as shown in Figure II: 1-8 for the cassette sampler and Figure II: 1-9 for the cyclone sampler.
- d. Visually inspect all Tygon tubing connections.
- e. Wet the inside of the electronic flow cell with the soap solution supplied by pushing on the button several times.
- f. Turn on the pump and adjust the pump rotameter, if available, to the appropriate flow rate.
- g. Press the button on the electronic bubble meter. Visually capture a single bubble and electronically time the bubble. The accompanying printer will automatically record the calibration reading in liters per minute.
- h. Repeat the step until two readings are within 2%.

- i. If necessary, adjust the pump while it is still running.
- j. Repeat the procedures described above for all pumps to be used for sampling. The same cassette and filter may be used for calibrations involving the same sampling method.

**2. Precision Rotameter Method.**

The precision rotameter, Figure II:1-10, is a secondary calibration device. If it is to be used in place of a primary device such as a bubble meter, take care to ensure that any error introduced will be minimal and noted. **NOTE:** Using precision rotameters for pump calibration should be avoided if possible. Tests have indicated significant measurement errors due to pump pulsations. These pulsations are typically not observable by the user.

a. **Replacing the Bubble Meter.** The precision rotameter may be used for calibrating the personal sampling pump in lieu of a bubble meter, provided it is:

- Calibrated regularly, at least monthly, with an electronic bubble meter or a bubble meter, as described in [Appendix II: 1-3](#).
- Disassembled, cleaned as necessary, and recalibrated. (It should be used with care to avoid dirt and dust contamination, which may affect the flow.)
- Not used at substantially different temperature and/or pressure from conditions present when the rotameter was calibrated against the primary source.
- Used in such a way that the pressure drop across it is minimized.

b. **Unusual Conditions.** If altitude or temperature at the sampling site are substantially different from those at the calibration site, it is necessary to calibrate the precision rotameter at the sampling site.

**3. Manual Buret Bubble Meter Method.** See [Appendix II: 1-3](#).

**7. FILTER WEIGHING.**

The SLTC is providing pre-weighed filters for gravimetric analysis. These filters should reduce sample preparation time by CSHO's in the field because the filters are weighed at SLTC and shipped to the field assembled and ready for use in inspections. The filters will then be returned to SLTC for gravimetric and any other additional analyses.

- 1. **THE FILTER MEDIA** is 37-mm diameter, low-ash polyvinyl chloride. These filters should be used for silica (quartz) analysis, aluminum, and any other appropriate substance having a high PEL or requiring gravimetric analysis. The filters may be used without the cyclone attached for total dust analyses. Please indicate on the 91A form all analytes of interest. If gravimetric analysis yields a result less than the PEL for the requested substance(s), no further analysis will be provided unless specifically requested. **The filter/cassette unit, shown in Figure II:1-11a, is expensive; please only use it for samples requiring crystalline silica gravimetric analysis or other gravimetric analysis.** [Appendix II: 1-7](#) is a partial listing of suggested substances that can be sampled and gravimetrically analyzed using the pre-weighed cassettes.

**FIGURE II:1-10. A SINGLE-COLUMN PRECISION ROTAMETER CAN BE USED AS A SECONDARY CALIBRATION DEVICE**

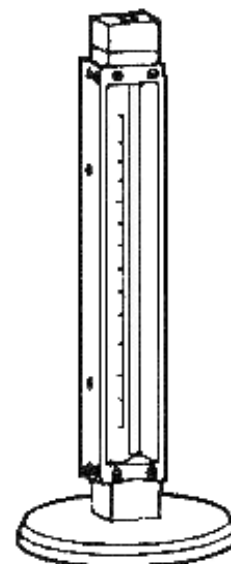

**FIGURE II:1-11a. THE FILTER/CASSETTE UNIT**

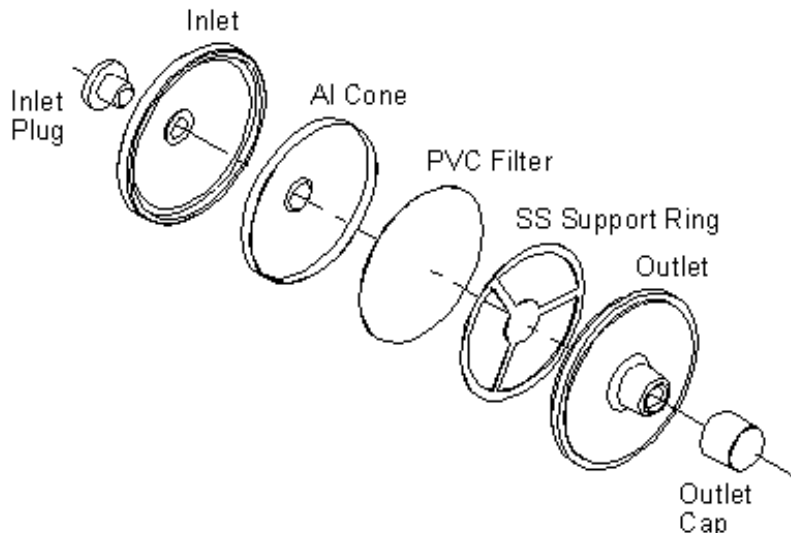

- 2. **AVAILABILITY.** These filters are shipped pre-weighed and assembled in the cassettes. They are available directly from the SLTC or through the CTC "Expendables Supplies" li in the "OSHA Property Management Inventory System (OPMIS)."

(Listed as "Cassette, Aerosol, 37MM, Preassembled, \*\*Preweighed at SLTC\*\*, #FES0000161).

3. **INSTRUCTIONS FOR CALIBRATION, SAMPLING AND SUBMISSION OF SAMPLES.** Be sure to follow all appropriate protocols for calibration, sampling and submission of samples. A blank should be included with every set of samples. Due to the slightly smaller size of the sampler, check frequently to prevent filter overloading. This can be accomplished by viewing the inlet sampling port of the cassette. Visual observation of the airborne dust concentration around the worker may assist in determining how frequently to check the filter for overloading.

1. Two versions of the pre-weighed cassettes exist. New cassettes have a stainless steel filter support (shown in Figure II:1-11b), and older cassettes have a Tyvek® backup pad. The stainless steel support seems to be less affected by humidity (providing a more stable blank weight) than the old pad. Both styles may even be used in a single inspection; however, **it is very important that the blanks submitted with a set of samples have the same backup pad as the samples.**
2. As shown in Figure II:1-11c, the inlet side of the cassette is marked on the polystyrene cassette. This is the side of the filter cassette with the metallic antistatic shield. The Tyvek® backup pad or the stainless steel support is visible from the outlet side of the assembly. Each of the filter assemblies is bar coded for weighing purposes. To aid in the tracking of the filters, **please use the barcode number for the sample submission number when filling out OSHA form 91A.** For your convenience, the barcode number is printed on a label attached to the outlet side of the cassette.

**FIGURE II:1-11b. STAINLESS STEEL FILTER SUPPORT**

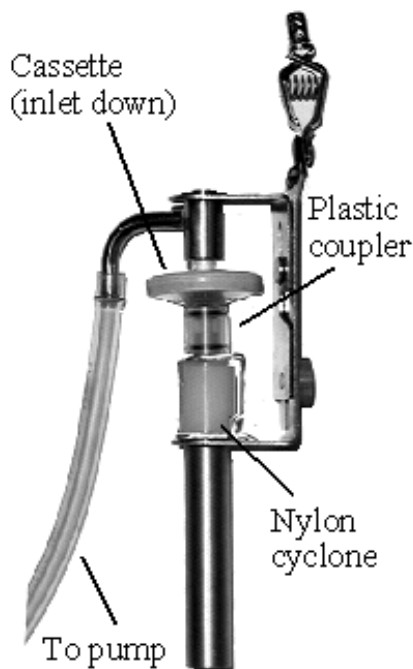

**FIGURE II:1-11c. SIDES OF THE FILTER CASSETTE**



3. The filter/cassette assembly can be used with both nylon cyclone and holder assemblies currently in field use; however, the standard MSA coupler (used with a standard 2- or 3-piece cassette) will not fit these cassettes. Another coupler available from MSA (part #457391), which is plastic instead of stainless steel, can be obtained from CTC.

**FIGURE II:1-11d. MSA CYCLONE HOLDER WITH CASSETTE**



**FIGURE II:1-11e. BENDIX HOLDER WITH CASSETTE**

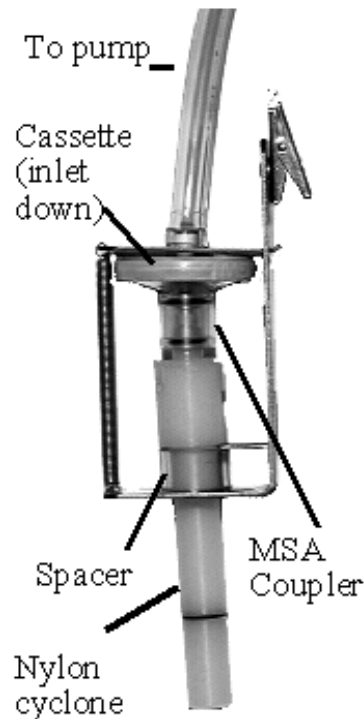

4. If a compliance officer wishes to employ field balance weighing techniques instead of the SLTC weighing program, please consult a prior version of the Technical Manual (Sampling Chapter, Section VI) or contact the SLTC for further instructions.

**7. BIBLIOGRAPHY.**

American Industrial Hygiene Association (AIHA). 1987. *Fundamentals of Analytical Procedures in Industrial Hygiene*. AIHA: Akron, OH.

Hesketh, H.E. 1986. *Fine Particles in Gaseous Media*. Lewis Publishers, Inc.: Chelsea, MA.

Lioy, P.J. 1989. *Air Sampling Instruments for Evaluation of Atmospheric Contaminants*. American Conference of Governmental Industrial Hygienists: Cincinnati.

Lodge, J.P., Jr. (Ed.) 1988. *Methods of Air Sampling and Analysis*. Lewis Publishers, Inc.: Chelsea, MA.

National Institute for Occupational Safety and Health (NIOSH). 1977. *Occupational Exposure Sampling Strategy Manual*. DHEW (NIOSH) Publication No. 77-173. U. S. Government Printing Office, Washington, D.C.

Occupational Safety and Health Administration, U.S. Dept. of Labor. 1995. OSHA Computerized Information System (OCIS) Chemical Sampling Information. U.S. Government Printing Office: Washington, D.C.

## **APPENDIX II:1-1. DETECTOR TUBES AND PUMPS**

### **PRINCIPLE AND DESCRIPTION.**

Detector tube pumps are portable equipment which, when used with a variety of commercially available detector tubes, are capable of measuring the concentrations of a wide variety of compounds in industrial atmospheres.

Operation consists of using the pump to draw a known volume of air through a detector tube designed to measure the concentration of the substance of interest. The concentration is determined by a colorimetric change of an indicator which is present in the tube contents. Most detector tubes can be obtained locally.

### **APPLICATIONS AND LIMITATIONS.**

Detector tubes and pumps are screening instruments which may be used to measure more than 200 organic and inorganic gases and vapors or for leak detection. Some aerosols can also be measured.

Detector tubes of a given brand are to be used only with a pump of the same brand. The tubes are calibrated specifically for the same brand of pump and may give erroneous results if used with a pump of another brand.

A limitation of many detector tubes is the lack of specificity. Many indicators are not highly selective and can cross-react with other compounds. Manufacturers' manuals describe the effects of interfering contaminants.

Another important consideration is sampling time. Detector tubes give only an instantaneous interpretation of environmental hazards. This may be beneficial in potentially dangerous situations or when ceiling exposure determinations are sufficient. When long-term assessment of occupational environments is necessary, short-term detector-tube measurements may not reflect time-weighted average levels of the hazardous substances present.

Detector tubes normally have a shelf life at 25 °C of one to two years. Refrigeration during storage lengthens the shelf life. Outdated detector tubes (i.e., beyond the printed expiration date) should never be used. The OSHA Training Institute can sometimes use these outdated tubes for training purposes.

Several different types and brands of detector tubes have been evaluated for screening and compliance use by SLTC. Information regarding these evaluations can be obtained by contacting SLTC.

### **PERFORMANCE DATA.**

Specific manufacturers' models of detector tubes are listed in the [Chemical Sampling Information](#). The specific tubes listed are designed to cover a concentration range that is near the PEL. Concentration ranges are tube-dependent and can be anywhere from one-hundredth to several thousand ppm. The limits of detection depend on the particular detector tube. Accuracy ranges vary with each detector tube.

The pump may be hand-held during operation (weight: 8-11 ounces), or it may be an automatic type (weight: about 4 pounds) that collects a sample using a preset number of pump strokes. A full pump stroke for either type of short-term pump has a volume of about 100 ml.

In most cases where only one pump stroke is required, sampling time is about one to two minutes. Determinations for which more pump strokes are required take proportionately longer.

Contact the CTC for information regarding long-term maintenance.

### **LEAKAGE TEST.**

Each day prior to use, perform a pump leakage test by inserting an unopened detector tube into the pump and attempt to draw in 100 ml of air. After a few minutes, check for pump leakage by examining pump compression for bellows-type pumps or return to resting position for piston-type pumps. Automatic pumps should be tested according to the manufacturer's instructions.

In the event of leakage that cannot be repaired in the field, send the pump to the CTC for repair. Record that the leakage test was made on the Direct-Reading Data Form (OSHA-93).

### **CALIBRATION TEST.**

Calibrate the detector tube pump for proper volume measurement at least quarterly. Simply connect the pump directly to the bubble meter with a detector tube in-line. Use a detector tube and pump from the same manufacturer.

Wet the inside of the 100 ml bubble meter with soap solution. For volume calibration, experiment to get the soap bubble even with the zero (0) ml mark of the buret.

For piston-type pumps, pull the pump handle all the way out (full pump stroke) and note where the soap bubble stops; for bellows-type pumps, compress the bellows fully; for automatic pumps, program the pump to take a full pump stroke. For either type pump, the bubble should stop between the 95 ml and 105 ml marks. Allow 4 minutes for the pump to draw the full amount of air (This time interval varies with the type of detector tube being used in-line with the calibration setup).

Also check the volume for 50 ml (one-half pump stroke) and 25 ml (one-quarter pump stroke) if pertinent. As in Section 1 above,  $\pm 5\%$  error is permissible. If the error is greater than  $\pm 5\%$ , send the pump to CTC for repair and recalibration. Record the calibration information required on the Calibration Log (OSHA-93).

It may be necessary to clean or replace the rubber bung or tube holder if a large number of tubes have been taken with any pump.

### **ADDITIONAL INFORMATION.**

*DRAEGER, MODEL 31 (BELLOWS).* When checking the pump for leaks with an unopened tube, the bellows should not be completely expanded after 10 minutes. For the *DRAEGER ACCURO PUMP (BELLOWS)*, a 15-minute period is used and the end-of-stroke indicator should not be noticeable after this period.

*DRAEGER, QUANTIMETER 1000, MODEL 1 (AUTOMATIC).* A battery pack is an integral part of this pump. The pack must be charged prior to initial use. One charge is good for 1000 pump strokes. During heavy use, it should be recharged daily. If a "U" (undervoltage) message is continuously displayed in the readout window of this pump, the battery pack should be immediately recharged. A leak test is performed by turning the system on, setting the pump stroke indicator to "2" or greater, inserting an unopened tube into the holder and pressing the start/stop key. When the second stroke has not started after 30 minutes, the device is considered sufficiently gas-tight.

*MATHESON-KITAGAWA, MODEL 8014-400A (PISTON).* When checking the pump for leaks with an unopened tube, the pump handle should be pulled back to the 100-ml mark and locked. After 2 minutes, the handle should be released carefully. It should return to zero or resting position. After taking 100-200 samples, the pump should be cleaned and relubricated. This involves removing the piston from the cylinder, removing the inlet and pressure-relief valve from the front end of the pump, cleaning, and relubricating.

*MINE SAFETY APPLIANCES, SAMPLAIR PUMP, MODEL A, PART NO. 46399 (PISTON).* The pump contains a flow-rate control orifice protected by a plastic filter which periodically needs to be cleaned or replaced. To check the flow rate, the pump is connected to a buret and the piston is withdrawn to the 100-ml position with no tube in the tube holder. After 24-26 seconds, 80 ml of air should be admitted to the pump. Every 6 months the piston should be relubricated with the oil provided.

*MINE SAFETY APPLIANCES KWIK DRAW™ SAMPLING PUMP, PART NO. 487500 (BELLOWS).* The pump contains a filter disk that needs periodic cleaning or replacement. The bellows shaft can be cleaned and lubricated with automotive wax if operation becomes jerky. This pump is tested for leakage by inserting an unopened tube into the holder, deflating the pump fully and releasing. After 10 minutes the distance of the bellows to the frame is  $\frac{1}{2}$  inch or greater.

*NEXTEQ, LLC (GASTEC MODEL GV-100 PISTON SAMPLING PUMP).* When checking the pump for leaks, first confirm that the inlet clamping nut is firmly tightened. Next, push the pump handle fully in and align the guide marks on the pump shaft and handle. Then insert a fresh unbroken tube into the rubber inlet of the pump. Pull out the handle fully until it is locked, and wait 1 minute. Unlock the handle (by turning it more than  $\frac{1}{4}$  turn) and guide it back gradually applying a little force. Otherwise, the handle will spring back due to the vacuum in the cylinder and may damage the internal parts. Confirm the handle returns to the initial position and the guideline on the pump shaft is not seen. If this is not confirmed, follow the maintenance procedures explained in the operations manual for the Model GV-100 pump, or contact your Nextteq representative for maintenance assistance. The maintenance procedures involve leak checks on the inlet clamping nut and rubber inlet, and performing pump cylinder lubrication. *Nextteq is Gastec's exclusive U.S. master wholesale distributor. The Gastec Corporation manufactures Gastec tubes and pumps.*

### **SPECIAL CONSIDERATIONS.**

Detector tubes should be refrigerated when not in use to prolong shelf life. Detector tubes should not be used when cold. They should be kept at room temperature or in a shirt pocket for one hour prior to use. Lubrication of the piston pump may be required if volume error is greater than 5%.

## **APPENDIX II: 1-2. ELECTRONIC FLOW CALIBRATORS**

### **DESCRIPTION.**

These units are high-accuracy electronic bubble flow meters that provide instantaneous airflow readings and a cumulative averaging of

multiple samples. These calibrators measure the flow rate of gases and report volume per unit of time.

The timer is capable of detecting a soap film at 80-microsecond intervals. This speed allows under steady flow conditions an accuracy of  $\pm 0.5\%$  of any display reading. Repeatability is  $\pm 0.5\%$  of any display.

The range with different cells is from 1 ml/min to 30 L/min. Battery power will last 8 hours with continuous use. Charge for 16 hours. Can be operated from A/C charger.

#### **MAINTENANCE OF CALIBRATOR.**

**1. Cleaning Before Use.** Remove the flow cell and gently flush with tap water. The acrylic flow cell can be easily scratched. Wipe with cloth only. Do not allow center tube, where sensors detect soap film to be scratched or get dirty. *Never clean with acetone, alcohol or other cleaning solutions.* Use only soap and warm water. When cleaning prior to storage, allow flow cell to air dry. If stubborn residue persists, it is possible to remove the bottom plate. Squirt a few drops of soap into the slot between base and flow cell to ease removal.

**2. Leak Testing.** The system should be leak checked at 6" H<sub>2</sub>O by connecting a manometer to the outlet boss and evacuating the inlet to 6" H<sub>2</sub>O. No leakage should be observed.

**3. Verification of Calibration.** The calibrator is factory calibrated using a standard traceable to National Institute of Standards and Technology, formerly called the National Bureau of Standards, (NBS). Attempts to verify calibrator against a glass one-liter burette should be conducted at 1000 ml/min for maximum accuracy. The calibrator is linear throughout the entire range.

#### **SHIPPING AND HANDLING.**

When transporting, especially by air, it is important that one side of the seal tube which connects the inlet and outlet boss, be removed for equalizing internal pressure within the calibrator. Do not transport unit with soap solution or storage tubing in place.

#### **PRECAUTIONS AND WARNINGS.**

1. Avoid the use of chemical solvents on flow cell, calibrator case and faceplate. Generally, soap and water will remove any dirt.

2. Never pressurize the flow cell at any time with more than 25 inches of water pressure.

3. Do not charge batteries for longer than 16 hours.

4. Do not leave A/C adapter plugged into calibrator when not in use, as this could damage the battery supply.

5. Black close fitting covers help to reduce evaporation of soap in the flow cell when not in use.

6. Do not store flow cell for a period of one week or longer with soap. Clean and store dry.

7. The Calibrator Soap is a precisely concentrated and sterilized solution formulated to provide a clean, frictionless soap film bubble over the wide, dynamic range of the calibrator. The sterile nature of the soap is important in the prevention of residue build-up in the flow cell center tube, which could cause inaccurate readings. The use of any other soap is not recommended. Proper soap solution is available from CTC's expendable supplies program (AESP).

#### **APPENDIX II:1-3. MANUAL BURET BUBBLE METER TECHNIQUE**

When a sampling train requires an unusual combination of sampling media (e.g., glass fiber filter preceding impinger), the same media/devices should be in line during calibration. Calibrate personal sampling pumps before and after each day of sampling.

#### **BUBBLE METER METHOD**

1. Allow the pump to run 5 minutes prior to voltage check and calibration.

2. Assemble the cassette filter holder using the appropriate filter for the sampling method. If a cassette adaptor is used, care should be taken to ensure that it does not come in contact with the back-up pad.

**NOTE:** When calibrating with a bubble meter, the use of cassette adaptors can cause moderate to severe pressure drop in the sampling train, which will affect the calibration result. If adaptors are used for sampling, then they should be used when calibrating.

3. Connect the collection device, tubing, pump and calibration apparatus as shown in Figures II:1-12 and II:1-13.

#### **FIGURE II:1-12. CALIBRATION SET-UP FOR PERSONAL SAMPLING WITH FILTER CASSETTE.**

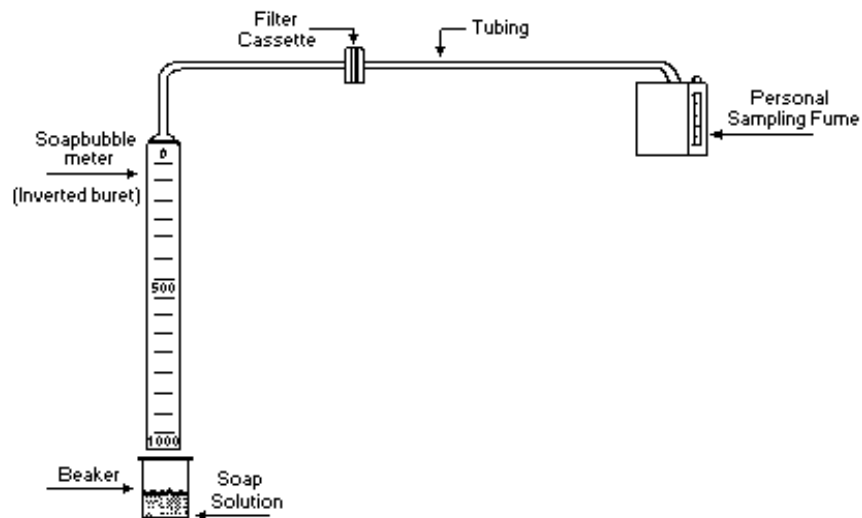

**FIGURE II:1-13 CALIBRATION OF CYCLONE RESPIRABLE DUST SAMPLER USING A BUBBLER METER.**

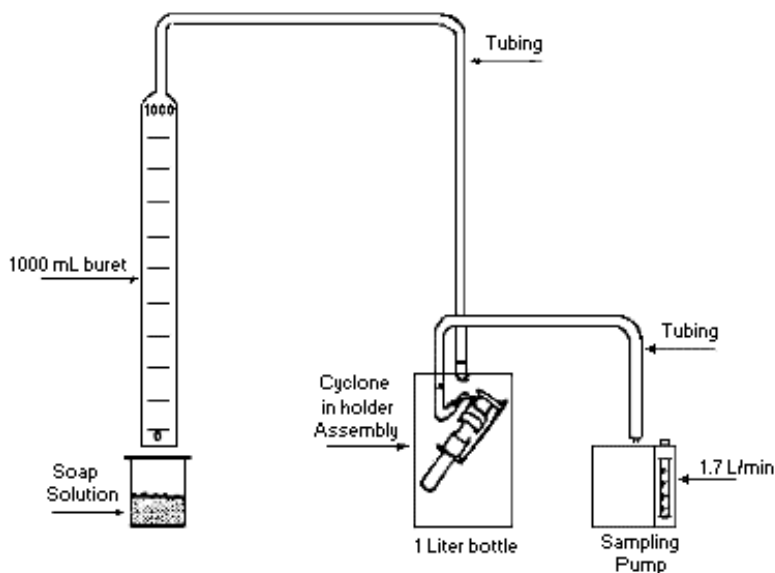

4. A visual inspection should be made of all Tygon tubing connections.
5. Wet the inside of a 1-liter buret with a soap solution.
6. Turn on the pump and adjust the pump rotameter to the appropriate flow rate setting.
7. Momentarily submerge the opening of the buret in order to capture a film of soap.
8. Draw two or three bubbles up the buret in order to ensure that at least one bubble will complete its run.
9. Visually capture a single bubble and time the bubble from 0 to 1000 ml for high flow pumps or 0 to 100 ml for low flow pumps.
10. The timing accuracy must be within  $\pm 1$  second of the time corresponding to the desired flow rate. If the time is not within the range of accuracy, adjust the flow rate and repeat steps 9 and 10 until the correct flow rate is achieved. Perform steps 9 and 10 at least twice.
11. While the pump is still running, mark the pump or record on the OSHA-91 the position of the center of the float in the pump rotameter as a reference.
12. Repeat the procedures described above for all pumps to be used for sampling. The same cassette and filter may be used for all calibrations involving the same sampling method.

**APPENDIX II:1-4. SHELF LIFE OF SAMPLING MEDIA PROVIDED BY SLTC**

<b>Sampling medium</b>	<b>Shelf life</b>	<b>Comments</b>
Sodium hydroxide (all normalities)	6 months	
Hydrochloric acid Sulfuric acid Methanol in water	1 year	Same for all concentrations of all solutions.
Solution for bis-chloromethyl ether (BCME) and chloromethyl methyl ether (CMME)	2 months	Prepared on request*
Hydroxylammonium chloride solutions (for ketene collection)	2 weeks	Prepared on request*
Hydroxylammonium chloride-sodium hydroxide mixed solutions (for ketene collection)	Stable only 2 hours	Must be prepared fresh just prior to use.
Folin's reagent	5 days	Prepared on request*
Passive monitors		Must be used before the expiration date (if given) printed on the monitor package.
Nitrogen oxides collection tubes		Should be stored in a refrigerator.
Sampler for ozone (Nitrite-treated filter collection device)	28 days	Prepared on request*
Coated filter sampler for di-isocyanates (MDI, HDI, TDI, etc.)	1 year	Prepared on request*
Treated filter sampler for collection of anhydrides	30 days	Prepared on request*

\* Please notify SLTC of need two days in advance to allow for preparation time.

## **APPENDIX II:1-5. SAMPLING FOR SPECIAL ANALYSES**

### **CRYSTALLINE SILICA SAMPLES ANALYZED BY X-RAY DIFFRACTION (XRD).**

#### **Air Samples.**

Respirable dust samples for quartz, cristobalite, and tridymite are analyzed by X-ray diffraction (XRD). XRD is the preferred analytical method due to its sensitivity, minimum requirements for sample preparation and ability to identify polymorphs (different crystalline forms) of free silica.

The analysis of crystalline free silica by XRD requires that the particle size distribution of the samples be matched as closely as possible to the standards. This is best accomplished by collecting a respirable sample.

Respirable dust samples are collected on a tared low ash PVC filter using a 10-mm nylon cyclone at a flow rate of 1.5 to 2.0 L/min. A sample not collected in this manner is considered a total dust (or nonrespirable) sample. Because of the difficulty in matching sample particle size with analytical standards, CSHO's are discouraged from submitting total dust samples. If the sample collected is nonrespirable, the laboratory must be advised on the OSHA-91 form.

Samples are analyzed for cristobalite or tridymite only upon request.

Quartz (also cristobalite and tridymite) is initially identified by its major (primary) X-ray diffraction peak. A few substances also have peaks near the same location, and it is necessary to confirm quartz (also cristobalite or tridymite) using secondary and/or tertiary peaks. To assist the analyst in identifying interference, the CSHO should provide information concerning potential presence of other substances in the workplace. The following substances should be noted:

- Aluminum phosphate
- Feldspars (microcline, orthoclase, plagioclase)
- Graphite
- Iron carbide



- Lead sulfate
- Micas (biotite, muscovite)
- Montmorillonite
- Potash
- Sillimanite
- Silver chloride
- Talc
- Zircon (Zirconium silicate).

Total air volume shall accompany all filter samples. If a field balance is used to provide pre- and post weights instead of SLTC- or CTC-supplied pre-weighed filters, sample weights shall also accompany the filter samples. Sample weights of 0.5 mg to 3.0 mg are preferred. For those samples that are still weighed in the field, do not submit a sample(s) unless its weight or the combined weights of all particulate filters representing an individual exposure exceed 0.04 mg. If heavy sample loading is noted during the sampling period, it is recommended that the filter cassette be changed to avoid collecting a sample with a weight greater than 5.0 mg.

Laboratory results for air samples are usually reported under one of four categories:

- **Percent Quartz (or Cristobalite).** Applicable for a respirable sample in which the amount of quartz (or cristobalite) in the sample was confirmed.
- **Less Than or Equal to Value in Units of Percent.** Less than or equal to values are used when the adjusted 8-hour exposure is found to be less than the PEL, based on the sample's primary diffraction peak. The value reported represents the maximum amount of quartz (or cristobalite) that could be present. However, the presence of quartz (or cristobalite) was not confirmed using secondary and/or tertiary peaks in the sample since the sample could not be in violation of the PEL.
- **Approximate Values in Units of Percent.** The particle size distribution in a total dust sample is unknown and error in the XRD analysis may be greater than for respirable samples. Therefore, for total dust samples, an approximate result is given.
- **Nondetected.** A sample reported as nondetected indicates that the quantity of quartz (or cristobalite) present in the sample is not greater than the detection limit of the instrument. The detection limit is usually 10 µg for quartz and 30 µg for cristobalite. If less than a full-shift sample was collected, the CSHO should evaluate a nondetected result to determine whether adequate sampling was performed. If the presence of quartz (or cristobalite) is suspected in this case, the Industrial Hygienist may want to sample for a longer period of time to increase the sample weights.

### **Bulk Samples.**

Bulk samples should be submitted for all silica analyses, if possible. They have the following purposes:

- To confirm the presence of quartz or cristobalite in respirable samples, or to assess the presence of other substances that may interfere in the analysis of respirable samples.
- To determine the approximate percentage of quartz (or cristobalite) in the bulk sample.
- To support Hazard Communication inspections.

A bulk sample must be representative of the airborne free silica content of the work environment sampled; otherwise, it will be of no value.

The laboratory's order of preference for bulk samples for an evaluation of personal exposure is:

- A representative settled-dust (rafter) sample.
- A bulk sample of the raw material used in the manufacturing process (most practical if used for Hazard Communication inspections).

The type of bulk sample submitted to the laboratory should be stated on the OSHA-91 form and cross-referenced to the appropriate air samples.

Normally, any reported results for bulk sample analysis for quartz (also cristobalite or tridymite) will be approximate because of the difficulty in matrix and particle size matching of the bulk material with the analytical standards used during analysis.

### **SAMPLE CALCULATIONS FOR CRYSTALLINE SILICA EXPOSURES.**

Where the employee is exposed to combinations of silica dust (i.e., quartz, cristobalite, and tridymite), the additive effects of the mixture will be considered.

For the PEL calculation specified in 29 CFR 1910.1000, Table Z-

3, the percent silica will be determined by doubling the percentage of cristobalite and/or tridymite and adding it to the percentage of quartz, according to the following formula. The PEL mixture pertains to the respirable fraction. (Refer to Figure II: 1-14.)

Two consecutive samples from the same employee taken for a combined exposure to silica dusts have the following results, shown

below in Figure II: 1-14, Sample Calculation for Silica Exposure.

**FIGURE II:1-14. SAMPLE CALCULATION FOR SILICA EXPOSURE**

<b>Sample</b>	<b>Sampling period (min)</b>	<b>Total volume (L)</b>	<b>Respirable weight (mg)</b>	<b>Respirable concentration (mg/m<sup>3</sup>)</b>	<b>Laboratory results (%)</b>
A	238	405	0.855	2.1	5.2 quartz 2.3 cristobalite ND tridymite
B	192	326	0.619	1.9	4.8 quartz 1.7 cristobalite ND tridymite
Total	430	731	1.474		

**Key:** ND = Not detectable.

Calculation of the TWA from the sampling and analytical data:

**Step 1.** Calculate the percentage of quartz, cristobalite, and tridymite in the respirable particulate collected.

Quartz:  $5.2 (0.855/1.474) + 4.8 (0.619/1.474) = 3.0 + 2.0 = 5.0\%$

Cristobalite:  $2.3 (0.855/1.474) + 1.7 (0.619/1.474) = 1.3 + 0.7 = 2.0\%$

**Step 2.** Calculate the PEL for the mixture.

$$PEL_{\text{mixture}} = \frac{10 \text{ mg/m}^3}{\% \text{ quartz} + 2(\% \text{ cristobalite}) + 2(\% \text{ tridymite}) + 2}$$

$$= 10/[5.0 + 2(2.0) + 2(0) + 2] = 10/11.0 = 0.91 \text{ mg/m}^3$$

**Step 3.** Calculate the employee's exposure.

Exposure = (Sample wt. A + Sample wt. B)/Total volume =  $(0.855 + 0.619)/0.731 = 2.0 \text{ mg/m}^3$

**Step 4.** Adjust (where necessary) for less than 8-hour sampling period.

TWA =  $(2.0 \text{ mg/m}^3)[(430 \text{ min})/(480 \text{ min})] = 1.8 \text{ mg/m}^3$  **Step 5.** Calculate the severity of the exposure.  
 $(1.8 \text{ mg/m}^3)/(0.91 \text{ mg/m}^3) = 2.0$

### **SAMPLES ANALYZED BY INDUCTIVELY COUPLED PLASMA (ICP)**

#### **Metals.**

Where two or more of the following analytes are requested on the same filter, an ICP analysis may be conducted. However, the compliance officer should specify the metals of interest in the event samples cannot be analyzed by the ICP method. A computer printout of the following 13 analytes may be reported:

- Antimony
- Beryllium
- Cadmium\*
- Chromium
- Cobalt
- Copper
- Iron
- Lead
- Manganese
- Molybdenum
- Nickel

- Vanadium
- Zinc

\* Cadmium can be analyzed if air volumes are greater than 200 liters.

If requested, the laboratory can analyze for "solder-type" elements, such as:

- Antimony
- Beryllium
- Cadmium
- Copper
- Lead
- Silver
- Tin
- Zinc

Samples taken during abrasive blasting operations are no longer analyzed by ICP because of difficulties with heavy loadings. These samples can be analyzed by atomic absorption spectrometry (AAS) for specific metals (i.e, Pb, Cd, Cr, Fe).

#### **SAMPLES ANALYZED BY X-RAY FLUORESCENCE (XRF).**

Filter, wipe, and bulk samples can be qualitatively analyzed by XRF. Requests for XRF analyses should be preceded by a phone call to SLTC to determine the extent and value of the analysis. Packaging and shipping of such samples should be done in a manner consistent with directions previously given in this chapter.

#### **APPENDIX II:1-6. SAMPLING AND ANALYTICAL ERRORS (SAE's)**

##### **DEFINITION OF SAE's.**

When an employee is sampled and the results analyzed, the measured exposure will rarely be the same as the true exposure. This variation is due to sampling and analytical errors, or SAE's. The total error depends on the combined effects of the contributing errors inherent in sampling, analysis, and pump flow.

##### **Definition of Confidence Limits.**

Error factors determined by statistical methods shall be incorporated into the sample results to obtain the lowest value that the true exposure could be (with a given degree of confidence) and also the highest value the true exposure could be (also with some degree of confidence).

The lower value is called the lower confidence limit (LCL), and the upper value is the upper confidence limit (UCL). These confidence limits are termed one-sided since the only concern is with being confident that the true exposure is on one side of the PEL.

##### **DETERMINING SAE's.**

SAE's that provide a 95% confidence limit have been developed and are listed on each OSHA-91B report form (most current SAE's). If there is no SAE listed in the OSHA-91B for a specific substance, call the SLTC. If using detector tubes or direct-reading instruments, use the SAE's provided by the manufacturer.

##### **ENVIRONMENTAL VARIABLES.**

Environmental variables generally far exceed sampling and analytical errors. Samples taken on a given day are used by OSHA to determine compliance with PEL's. However, where the employer has previously monitored the work area, the CSHO should review the long-term pattern and compare it with the results. When OSHA's samples fit the long-term pattern, it helps to support the compliance determination. When OSHA's results differ substantially from the historical pattern, the CSHO should investigate the cause of this difference and perhaps conduct additional sampling.

##### **CONFIDENCE LIMITS.**

One-sided confidence limits can be used to classify the measured exposure into one of three categories:

1. If the measured results do not exceed the standard and the UCL also does not exceed the standard, we can be 95% confident that the employer is in compliance. (See Equation II: 1-6E.)
2. If the measured exposure exceeds the PEL and the LCL of that exposure also exceeds the PEL, we can be 95% confident that the employer is in noncompliance, and a violation is established. (See [Equation II: 1-6F.](#))
3. If the measured exposure does not exceed the PEL, but the UCL of that exposure does exceed the PEL, we cannot be 95% confident that the employer is in compliance. (See [Equation II: 1-6E.](#)) Likewise, if the measured exposure exceeds the PEL, but the LCL of that exposure is below the PEL, we cannot be 95% confident that the employer is in noncompliance. (See Equation II: 1-6F.) In both of these cases, the measured exposure can be termed a "possible overexposure."

A violation is not established if the measured exposure is in the "possible overexposure" region. It should be noted that the closer the LCL comes to exceeding the PEL, the more probable it becomes that the employer is in noncompliance.

If measured results are in this region, the CSHO should consider further sampling, taking into consideration the seriousness of the hazard, pending citations, and how close the LCL is to exceeding the PEL.

If further sampling is not conducted, or if additional measured exposures still fall into the "possible overexposure" region, the CSHO should carefully explain to the employer and employee representative in the closing conference that the exposed employee(s) may be overexposed but that there was insufficient data to document noncompliance. The employer should be encouraged to voluntarily reduce the exposure and/or to conduct further sampling to assure that exposures are not in excess of the standard.

### **SAMPLING METHODS.**

The LCL and UCL are calculated differently depending upon the type of sampling method used. Sampling methods can be classified into one of three categories:

**1. Full-period, Continuous Single Sampling.** Full-period, continuous single sampling is defined as sampling over the entire sample period with only one sample. The sampling may be for a full-shift sample or for a short period ceiling determination.

**2. Full-period, Consecutive Sampling.** Full-period, consecutive sampling is defined as sampling using multiple consecutive samples of equal or unequal time duration which, if combined, equal the total duration of the sample period. An example would be taking four 2-hour charcoal tube samples. There are several advantages to this type of sampling:

- If a single sample is lost during the sampling period due to pump failure, gross contamination, etc., at least some data will have been collected to evaluate the exposure.
- The use of multiple samples will result in slightly lower sampling and analytical errors.
- Collection of several samples allows conclusions to be reached concerning the manner in which differing segments of the work day affect overall exposure.

**3. Grab Sampling.** Grab sampling is defined as collecting a number of short-term samples at various times during the sample period which, when combined, provide an estimate of exposure over the total period. Common examples include the use of detector tubes or direct-reading instrumentation (with intermittent readings).

### **CALCULATIONS.**

If the initial and final calibration flow rates are different, a volume calculated using the highest flow rate should be reported to the laboratory. If compliance is not established using the lowest flow rate, further sampling should be considered.

Generally, sampling is conducted at approximately the same temperature and pressure as calibration, in which case no correction for temperature and pressure is required and the sample volume reported to the laboratory is the volume actually measured. Where sampling is conducted at a substantially different temperature or pressure than calibration, an adjustment to the measured air volume may be required depending on sampling pump used, in order to obtain the actual air volume sampled. The actual volume of air sampled at the sampling site is reported, and used in all calculations.

For particulates, the laboratory reports mg/m<sup>3</sup> of contaminant using the actual volume of air collected at the sampling site. The value in mg/m<sup>3</sup> can be compared directly to OSHA Toxic and Hazardous Substances Standards (e.g., 29 CFR 1910.1000).

The SLTC normally does not measure concentrations of gases and vapors directly in parts per million (ppm). Rather, most analytical techniques determine the total weight of contaminant in collection medium. Using the air volume provided by the CSHO, the lab calculates concentration in mg/m<sup>3</sup> and converts this to ppm at 25°C and 760 mm Hg using Equation II: 1-6A. This result is to be compared with the PEL without adjustment for temperature and pressure at the sampling site.

#### **Equation II:1-6A**

$$ppm(NTP) = mg/m^3(24.45) / Mwt$$

**Where: 24.45 = molar volume at 25°C (298°K) and 760 mm Hg**

**Mwt = molecular weight**

**NTP = Normal Temperature and Pressure, 25°C and 760 mm Hg.**

If it is necessary to know the actual concentration in ppm at the sampling site, it can be derived from the laboratory results reported in ppm at NTP by using the following equation:

#### **Equation II:1-6B**

$$ppm(PT) = ppm(NTP) [(760)/(P)] [(T)/(298)]$$

where:

**P** = sampling site pressure (mm of Hg)

**T** = sampling site temperature (°K)

**298** = temperature in degrees Kelvin (273°K + 25°)

#### Equation II:1-6C

Since  $ppm(NTP) = mg/m^3(24.45)/(Mwt)$

$$ppm(PT) = (mg/m^3)(24.45/Mwt)(760/P)(T/298)$$

**NOTE:** When a laboratory result is reported as  $mg/m^3$  contaminant, concentrations expressed as ppm (PT) cannot be compared directly to the standards table without converting to NTP.

**NOTE:** Barometric pressure can be obtained by calling the local weather station or airport, request the unadjusted barometric pressure. If these sources are not available, then a rule of thumb is: for every 1,000 feet of elevation, the barometric pressure decreases by 1 in. Hg.

#### CALCULATION METHOD FOR A FULL-PERIOD, CONTINUOUS SINGLE SAMPLE.

Obtain the full-period sampling result (value X), the PEL and the SAE. The SAE can be obtained from the *OSHA 91B* or by contacting *SLTC*.

Divide X by the PEL to determine Y, the exposure severity. That is:

#### Equation II:1-6D

$$Y = X/PEL$$

Compute the  $UCL_{95\%}$  as follows:

#### Equation II:1-6E

$$UCL_{95\%} = Y + SAE$$

Compute the  $LCL_{95\%}$  as follows:

#### Equation II:1-6F

$$LCL_{95\%} = Y - SAE$$

Classify the exposure according to the following classification system:

- If the  $UCL < 1$ , a violation does not exist.
- If  $LCL < 1$  and the  $UCL > 1$ , classify as possible overexposure.
- If  $LCL > 1$ , a violation exists.

#### SAMPLE CALCULATION FOR FULL-PERIOD, CONTINUOUS SINGLE SAMPLE.

A single fiberglass filter and personal pump were used to sample for carbaryl for a 7-hour period. The CSHO was able to document that the exposure during the remaining unsampled one-half hour of the 8-hour shift would equal the exposure measured during the 7-hour period. The laboratory reported  $6.07 mg/m^3$ . The SAE for this method is 0.23. The PEL is  $5.0 mg/m^3$ .

**Step 1.** Calculate the exposure severity.

$$Y = 6.07/5.0 = 1.21$$

**Step 2.** Calculate confidence limits.

$$LCL = 1.21 - 0.23 = 0.98$$

Since the LCL does not exceed 1.0, noncompliance is not established. The UCL is calculated:

$$UCL = 1.21 + 0.23 = 1.44$$

**Step 3.** Classify the exposure.

Since the LCL < 1.0 and the UCL > 1.0, classify as possible overexposure.

### CALCULATION METHOD FOR FULL-PERIOD CONSECUTIVE SAMPLING.

#### Equation II:1-6G

The use of multiple consecutive samples will result in slightly lower sampling and analytical errors than the use of one continuous sample since the inherent errors tend to partially cancel each other. The mathematical calculations, however, are somewhat more complicated. If preferred, the CSHO may first determine if compliance or noncompliance can be established using the calculation method noted for a full-period, continuous, single-sample measurement. If results fall into the "possible overexposure" region using this method, a more exact calculation should be performed using equation II:1-6G below.

Classify the exposure according to the following classification system:

- If UCL < 1, a violation does not exist.
- If LCL < 1, and the UCL > 1, classify as possible overexposure.
- If LCL > 1, a violation exists.

When the LCL < 1.0 and UCL > 1.0, the results are in the "possible overexposure" region and the CSHO must analyze the data using the more exact calculation for full-period consecutive sampling, as follows:

- Obtain  $X_1, X_2 \dots X_n$ , the n consecutive concentrations in one workshift and their time durations,  $T_1, T_2 \dots T_n$ .
- Also obtain the SAE in listed in the OSHA-91B sample report form.
- Compute the TWA exposure.
- Divide the TWA exposure by the PEL to find Y, the standardized average (TWA/PEL).
- Compute the UCL<sub>95%</sub> as follows:  
$$UCL_{95\%} = Y + SAE \text{ (Equation II: 1-6E)}$$
- Compute the LCL<sub>95%</sub> as follows:  
$$LCL_{95\%} = Y - SAE \text{ (Equation II: 1-6F)}$$

#### Equation II:1-6H

$$LCL = Y - \frac{SAE \sqrt{T_1^2 X_1^2 + T_2^2 X_2^2 + \dots + T_n^2 X_n^2}}{PEL(T_1 + T_2 + \dots + T_n)}$$

### SAMPLE CALCULATION FOR FULL-PERIOD CONSECUTIVE SAMPLING.

If two consecutive samples had been taken for carbaryl instead of one continuous sample, and the following results were obtained:

	-- Samples --	
	A	B
Sampling rate (L/min)	2.0	2.0
Time (min)	240	210
Volume (L)	480	420
Weight (mg)	3.005	2.457
Concentration (mg/m <sup>3</sup> )	6.26	5.85

The SAE for carbaryl is 0.23

**Step 1.** Calculate the UCL and the LCL from the sampling and analytical results:

$$TWA = [(6.26 \text{ mg/m}^3) 240 \text{ min} + (5.85 \text{ mg/m}^3) 210 \text{ min}] / 450 \text{ min} = 6.07 \text{ mg/m}^3$$

$$Y = 6.07 \text{ mg/m}^3/\text{PEL} = 6.07/5.0 = 1.21$$

$$\text{Assuming a continuous sample: LCL} = 1.21 - 0.23 = 0.98$$

$$\text{UCL} = 1.21 + 0.23 = 1.44$$

**Step 2.** Since the LCL < 1.0 and UCL > 1.0, the results are in the possible overexposure region, and the CSHO must analyze the data using the more exact calculation for full-period consecutive sampling as follows:

$$\text{LCL} = 1.21 - \frac{0.23\sqrt{(240\text{min})^2(6.26\text{mg/m}^3)^2 + (210\text{min})^2(5.85\text{mg/m}^3)^2}}{5.0\text{mg/m}^3(240+210\text{min})}$$

$$= 1.21 - 0.20 = 1.01$$

Since the LCL > 1.0, a violation is established.

**GRAB SAMPLING.**

If a series of grab samples (e.g., detector tubes) is used to determine compliance with either an 8-hour TWA limit or a ceiling limit, consult with the ARA for Technical Support regarding sampling strategy and the necessary statistical treatment of the results obtained.

**SAE's FOR EXPOSURE TO CHEMICAL MIXTURES.**

Often an employee is simultaneously exposed to a variety of chemical substances in the workplace. Additive toxic effects on a target organ is common for such exposures in many construction and manufacturing processes. This type of exposure can also occur when impurities are present in single chemical operations. Permissible exposure limits [or Threshold Limit Values (TLV's) such as the welding fume TLV of 5 mg/m<sup>3</sup>] for mixtures address the complex problem of additive exposures and their health effects. In addition, 29 CFR 1910.1000 contains a computational approach to assess exposure to a mixture. This calculation should be used when components in the mixture pose an additive threat to worker health. While these calculations can be used for synergistic exposures, a separate consideration must be performed. For synergistic mixtures, an individualized assessment of toxicity using the most current scientific data is conducted to consider the total physiologic burden. [See the [OSHA Field Inspection Reference Manual \(FIRM\)](#) for further details.] The SAE can still be calculated for synergistic mixtures; however, Equation II: 1-6I is adjusted to reflect any synergistic effects.

Whether using a single standard or the mixture calculation, the sampling and analytical error (SAE) of the individual constituents must be considered before arriving at a final compliance decision. These SAE's can be pooled and weighted to give a control limit for the additive mixture. To illustrate this control limit, the following example using the mixture calculation is expressed in the following equation.

**Equation II:1-6I**

$$E_m = C_1/L_1 + C_2/L_2 + \dots + C_n/L_n$$

Where:

- E<sub>m</sub> = equivalent exposure for a mixture  
(E<sub>m</sub> should be < 1 for compliance)
- C = concentration of a particular substance
- L = PEL

For example, to calculate exposure to three different but additive substances:

<b>Material</b>	<b>8-hr. exposure</b>	<b>8-hr TWA PEL (ppm)</b>	<b>SAE</b>
Substance 1	500	1000	0.089
Substance 2	80	200	0.11
Substance 3	70	200	0.18

Using Equation II: 1-6I: E<sub>m</sub> = 500/1000 + 80/200 + 70/200 = 1.25

Since  $E_m > 1$ , an overexposure appears to have occurred; however, the SAE for each substance also needs to be considered:

- Exposure ratio (for each substance)  $Y_n = C_n/L_n$
- Ratio to total exposure  $R_1 = Y_1/E_m \dots R_n = Y_n/E_m$

The SAE's (95% confidence) of the substance comprising the mixture can be pooled by:

$$(RS_t)^2 = [(R_1)^2 (SAE_1)^2 + (R_2)^2 (SAE_2)^2 + \dots (R_n)^2 (SAE_n)^2]$$

The mixture Control Limit (CL) is equivalent to:  $1 + RS_t$

If  $E_m < CL$ , then an overexposure has not been established at the 95% confidence level; further sampling may be necessary.

If  $E_m > 1$  and  $E_m > CL$ , then an overexposure has occurred (95% confidence).

Using the mixture data above:

$Y_1 = 500/1000$	$Y_2 = 80/200$	$Y_3 = 70/200$
$Y_1 = 0.5$	$Y_2 = 0.4$	$Y_3 = 0.35$
$R_1 = Y_1/E_m = 0.4$	$R_2 = 0.32$	$R_3 = 0.28$

$$(RS_t)^2 = (0.4)^2(0.089)^2 + (0.32)^2(0.11)^2 + (0.28)^2(0.18)^2$$

$$RS_t = [(RS_t)^2]^{1/2} = 0.071$$

$$CL = 1 + RS_t = 1.071$$

$$E_m = 1.25$$

Therefore  $E_m > CL$  and an overexposure has occurred within 95% confidence limits. This calculation is also used when considering a standard such as the one for total welding fumes. A computer program that will calculate a control limit for any additive mixture is available for personal computers. The program will run on any IBM-compatible computer in DOS and is available on the OSHA CD under the heading "software."

**APPENDIX II:1-7. PARTIAL LIST OF SUBSTANCES FOR AUTOWEIGHING SUBMISSION**

alpha-Alumina.....		Oil Mist (Mineral)	5010 5
Total dust.....	0160 15	Particulates not	
Respirable fraction..	A201 5	otherwise regulated	
Aluminum Metal (as Al).		(PNOR).....	
Total dust.....	A100 15	Total dust.....	9135 15
Respirable fraction..	A110 5	Respirable fraction..	9130 5
Ammonium sulfamate.....		Pentaerythritol.....	
Total dust.....	0185 15	Total dust.....	1987 15
Respirable fraction..	A111 5	Respirable fraction..	P157 5
Barium sulfate.....		Perlite.....	
Total dust.....	B101 15	Total dust.....	2035 15
Respirable fraction..	B104 5	Respirable fraction..	P101 5
Bismuth telluride		Plaster of paris.....	
Undoped.....		Total dust.....	2127 15
Total dust.....	0370 15	Respirable fraction..	P102 5
Respirable fraction..	B110 5	Portland cement.....	
Boron oxide.....		Total dust.....	0557 15
Total dust.....	0380 15	Respirable fraction..	P104 5
Calcium Carbonate.....		Rouge.....	
Total dust.....	0505 15	Total dust.....	2229 15
Respirable fraction..	C130 5	Respirable fraction..	R102 5
Calcium hydroxide.....		Silica, amorphous,	
		precipitated and gel.	9050
		Silica, amorphous,	
		diatomaceous earth,	
		containing less than	



Total dust.....	15
Respirable fraction..	5
Calcium oxide.....	0520 5
Calcium silicate.....	
Total dust.....	C112 15
Respirable fraction..	C122 5
Calcium sulfate.....	
Total dust.....	C104 15
Respirable fraction..	C123 5
Carbon black.....	0527 3.5
Cellulose.....	
Total dust.....	0575 15
Respirable fraction..	C124 5
Coal dust (less than 5% SiO(2)), respirable fraction..	9040
Coal dust (greater than or equal to 5% SiO(2)), respirable fraction.....	C120
Cotton Dust (The SLTC will supply special pre weighed cotton dust filters and cassettes on request.)	
Dicyclopentadienyl iron	
Total dust.....	0904 15
Respirable fraction..	D100 5
Emery.....	
Total dust.....	1016 15
Respirable fraction..	E102 5
Grain dust (oat, wheat, barley).....	G109 10
Glycerin (mist).....	
Total dust.....	1363 15
Respirable fraction..	G115 5
Graphite, synthetic....	
Total dust.....	1366 15
Respirable Fraction..	G100 5
Gypsum.....	
Total dust.....	1367 15
Respirable fraction..	G101 5
Kaolin.....	
Total dust.....	1568 15
Respirable fraction..	K100 5
Limestone.....	
Total dust.....	1593 15
Respirable fraction..	L100 5
Magnesite.....	
Total dust.....	M113 15
Respirable fraction..	1615 5
Magnesium oxide fume...	
Total Particulate....	1610 15
Marble.....	
Total dust.....	1626 15
Respirable fraction..	M114 5

1% crystalline silica	S112
Silica, crystalline	
cristobalite, respirable dust.....	9015
Silica, crystalline quartz, respirable dust.....	9010
Silica, crystalline	
tripoli (as quartz), respirable dust.....	S114
Silica, crystalline tridymite, respirable dust.....	9017
Silica, fused, respirable dust.....	9013
Silicates (less than 1% crystalline silica) Mica (respirable dust).....	
Soapstone, total dust	9025
Soapstone, respirable dust.....	S121
Talc (containing no asbestos), respirable dust.....	9030
Silicon.....	
Total dust.....	2235 15
Respirable fraction..	S120 5
Silicon carbide.....	
Total dust.....	2236 15
Respirable fraction..	S123 5
Starch.....	
Total dust.....	2263 15
Respirable fraction..	S124 5
Sucrose.....	
Total dust.....	2285 15
Respirable fraction..	S130 5
Tantalum, metal and oxide dust.....	2325 5
Titanium dioxide.....	
Total dust.....	2440 15
Vegetable oil mist....	
Total dust.....	V126 15
Respirable fraction..	V127 5
Zinc oxide fume.....	2610 5
Zinc oxide.....	
Total dust.....	Z102 15
Respirable fraction..	Z103 5
Zinc stearate.....	
Total dust.....	2616 15
Respirable fraction..	Z104 5
Zirconium compounds (as Zr).....	2620 5

[◀ TABLE OF CONTENTS](#)

[TOP ▲](#)

[NEXT CHAPTER ▶](#)

 [Back to Top](#)

[www.osha.gov](http://www.osha.gov)

[www.dol.gov](http://www.dol.gov)

---

[Contact Us](#) | [Freedom of Information Act](#) | [Customer Survey](#)  
[Privacy and Security Statement](#) | [Disclaimers](#)

---

Occupational Safety & Health Administration  
200 Constitution Avenue, NW  
Washington, DC 20210