

Impairment-Aware Manycasting Over Optical Burst-Switched Networks

Balagangadhar G. Bathula, Vinod M. Vokkarane, Rajesh R.C. Bikram

Department of Computer and Information Science, University of Massachusetts, Dartmouth, MA 02747

Email: {bbalagangadhar, vvokkarane, rrc}@umassd.edu

Abstract—In this paper we discuss the effect of physical impairments on manycasting service over the optical burst-switched (OBS) networks. Signal quality degradation in manycast networks is an important issue and it can occur due to fiber attenuation, splitter switch and amplified spontaneous noise in EDFA. These physical layer impairments causes the signal quality to be weak at the receiver and hence burst may not be detected or lost. Our objective is to select the manycast destinations based on the quality of signal received. We propose a new algorithm, *impairment aware - dynamic membership* (IADM) that takes into account of the physical layer impairments. Based on the simulation results we observe that IADM is more robust and practical, as bursts are scheduled not just on contention but also on the physical layer constraints¹.

Keywords: Manycast, OBS, Impairments, BER, and OSNR.

I. INTRODUCTION

The *manycast problem* is defined as follows: given a network $G(V, E)$, where V is the nodes and E edges, edge cost function is given by $g : E \rightarrow R^+$, an integer k , a source s , and the subset of candidate destinations $D_c \subseteq V$, $|D_c| = m \geq k$, where $|D_c|$ is the cardinality of the set D_c . We find a minimum-cost tree spanning k destinations in D_c . A manycast request is denoted by (s, D_c, k) . The selection of k destinations out of m by the IP layer is similar to the *random algorithm* in [1], which has been proved to have poor performance. Therefore, supporting manycasting at the OBS layer is necessary for the bandwidth-efficient manycasting.

Data loss in OBS network can occur either due to burst contention or impairments in the fiber. *Burst contention* is a special issue in OBS networks, which occurs due to burstiness of IP traffic and the lack of optical buffering. Contention occurs when multiple bursts contend for the same outgoing channel or wavelength. Many schemes have been proposed to resolve the burst contention issues [2]. However all these schemes assume that the underlying physical fiber media is ideal. In other words, the burst which is allocated a resource or wavelength is considered to be delivered error-free. But in practice this is not the case. Bursts are transmitted all-optically in the fiber and hence they have to traverse through many optical components, such as fiber, multiplexer, demultiplexer, splitters and optical amplifiers. This causes the signal to degrade in its quality. Received signal have amplified spontaneous emission (ASE) noise due to optical amplifiers in the network [3]. The common metric to characterize the signal quality is optical-signal-to-noise ratio (OSNR), defined as the ratio of power of signal received to power of the ASE noise [4]. Multicast capable switches cause optical power to split depending on number of output ports. The power will be reduced as the signal progresses towards destination, thus decreasing OSNR. Bit error rate (BER) of the signal is related

to OSNR. Decrease in OSNR causes an increase in BER. Thus a burst scheduled on a wavelength can be lost due to high BER of the signal. BER of the signal can be computed through q -factor [4]. If signal has low q , then BER of the signal is high and vice-verse. Thus a burst successfully scheduled on a wavelength, can be lost due to a low q . Therefore there is need to develop policies that implement manycasting considering both *burst contention* and *optical impairments*.

In this paper we modify the manycasting algorithms proposed in [2] by incorporating physical layer impairments. The rest of the paper is organized as follows: In Section II we discuss issues of supporting manycasting over OBS networks. In Section III we define the problem and obtain a measure to characterize the quality of link. In Section IV we describe the proposed the impairment-aware manycasting scheme. Simulation results are presented in Section V. Section VI concludes the paper.

II. MANCASTING SERVICE

The manycast request is simply denoted by (s, D_c, k) . The subtle difference between a manycast and a multicast is that in manycast the actual destinations to be chosen are determined instead of being given as in multicast. That is we have to send the burst to k destinations out of m possible candidate destinations. But due to the burst loss which occurs due to burst contention and/or signal degradation, there is no guarantee that there will be exactly k destinations that receive the burst. In general most of the solution approach of multicasting are largely applicable to manycast networks. Networks that can support the optical multicast can also support optical manycasting. Thus, manycasting can be implemented by multicast-capable optical cross-connect (MC-OXC) switches as shown in Fig.1. Now when it comes to routing the burst, shortest-path tree (SPT) can be computed, as given below:

- *Step 1:* Find the shortest path from source s to all the destinations in D_c . Let $D_c = \{d_1, d_2, \dots, d_m\}$ and minimum hop distance from s to d_i , where $1 \leq i \leq m$ is $\mathbb{H}^{(s)} = \{h_1, h_2, \dots, h_m\}$.
- *Step 2:* All the destinations in D_c are sorted in the non-decreasing order according to the shortest distance from source s to the destinations. Let D'_c be the new set in this order given by $\{d'_1, d'_2, \dots, d'_m\}$.

However it is not necessary that along shortest-path the optical signal has minimum degradation. Hence we make the manycast schemes aware of the physical-layer impairments.

III. PROBLEM STATEMENT

In this section we discuss the data loss due to physical impairments by computing q -factor. We first discuss the network architecture consisting of optical components that a signal traverses from source to destination in Section II-A. Then, in such network, we discuss the impairments in Section II-B. We compute the quality factor of the signal on per hop basis

¹This work was supported in part by the National Science Foundation (NSF) under grant CNS-0626798.

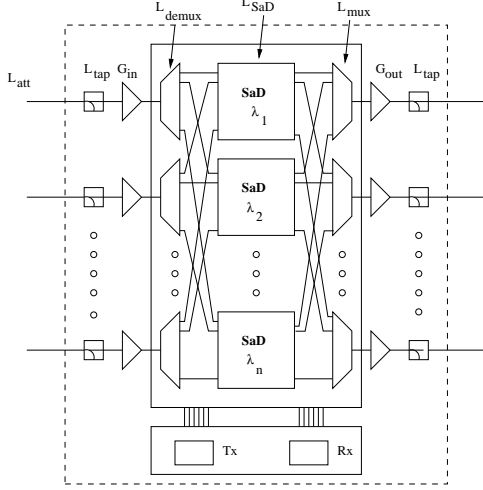

Fig. 1. MC-OXC based on Splitter-and-Delivery Architecture.

in Section II-C. The parameters used for the computation of q -factor are tabulated in Table. I.

A. Network Architecture

Figure. 1 shows the architecture for multicast-optical cross-connect (MC-OXC) using Splitter-and-Delivery (SaD) switch. As optical signal traverses from source to destination, it encounters losses due to optical switches, mux/demux, and fiber attenuation. Power loss can be compensated either by incorporating optical amplifiers or by increasing signal power at source. Fiber in-line amplification provided by the cascaded Erbium doped fiber amplifiers (EDFA), compensate the power loss due to attenuation in the fiber. However they increase the ASE noise in the channel, which in turn increases the BER. Increasing the power level in the channel causes non-linearity in the fiber. In this paper we consider in-line amplification of signal, and hence the effect of ASE noise on the signal quality is used for the computation of BER. An $N \times N$ SaD switch proposed in [5] is used in the architecture for manycasting. It consists of N power splitters and N^2 2×1 optical gates which are used to reduce crosstalk and N^2 2×1 photonic switches as shown in Fig. 2. These switches are assumed to be configurable and hence can be instructed to split the incoming signal to any of $i = 1, \dots, N$ output ports [6].

B. Calculation of q -factor on per-hop basis

- $L_{sp}(n) = 1/k(n)$ is loss due to the splitter at Node n , where $k(n)$ is the number of the output ports to which the signal is split, defined as *fan-out* of the splitter. If $k = 1$, then there is no splitting at the node and hence $L_{sp}(n) = 1$.
- L_n is physical distance between the nodes $\langle n, n+1 \rangle$, l is the distance between two amplifiers, then a , the number of amplifiers used between $\langle n, n+1 \rangle$ is given by,

$$a_n = \left\lceil \frac{L_n}{l} \right\rceil - 1. \quad (1)$$

We define l_n as the distance of fiber which is not been compensated by the in-line amplification and is given by

$$l_n = L_n - a_n \times l. \quad (2)$$

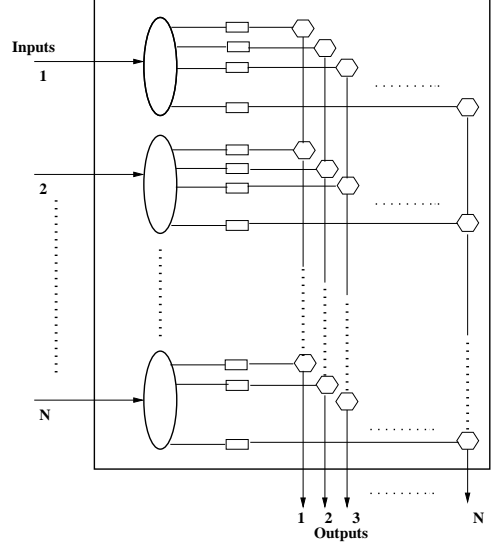

Fig. 2. An $N \times N$ SaD Switch.

- $L_{att}(n) = e^{-\alpha l_n}$ is loss due to the attenuation in the fiber, where α is the attenuation of the fiber.
- L_d , L_m , and L_t are defined as demultiplexer, multiplexer and tap losses, respectively.
- $L_{ins} = 2 \log_2 N L_s + 4 L_w$ is insertion loss [7] of the SaD switch, where L_s is switch element insertion loss and L_w is waveguide or coupling loss and N is number of fibers, which is equal to number of input/output ports of the switch.
- G_{in} and G_{out} , are gains of the input and the output EDFA respectively. Define $G_T = G_{in} G_{out}$ as the total gain provided by the amplifiers at the node.
- \bar{G} is the saturated gain of the in-line EDFA. This gain is set to compensate the fiber loss between consecutive amplifiers given by $\bar{G} = e^{\alpha l}$.
- $P(n)$, $P_{ase}(n)$ are the signal and ASE noise, power output at the n^{th} node respectively.
- B_o and B_e are the optical and electrical bandwidths.

Recursive Power Relations: Here we derive a recursive power relations similar to [3]. However the only difference, is in-line amplification is considered and we use SaD switch instead of OXC. The output power at the Node n is $P(n)$ and is given by,

$$\begin{aligned} P(n) &= G_{in} G_{out} L_d L_m L_t^2 L_{ins} L_{att}(n) L_{sp}(n-1) P(n-1). \\ &= G_T L_k L_{att}(n) L_{sp}(n-1) P(n-1). \\ &= G_T L_T(n-1) L_{sp}(n-1) P(n-1). \end{aligned} \quad (3)$$

where $L_k = L_d L_m L_t^2 L_{ins}$, this loss is a constant for any node and $L_T(n-1) = L_k L_{att}(n)$.

$$\begin{aligned} P_{ase}(n) &= P_{ase}(n-1) L_T(n-1) G_T + P_n L_T(n-1) \times \\ & \quad [G_{in} - 1] / L_t + P_n L_t [G_{out} - 1] + \\ & \quad P_n [\bar{G} - 1] a_n. \end{aligned} \quad (4)$$

where $P_n = 2n_{sp}hf_cB_o$ with typical values given in Table-I. Due to the in-line amplification of the signal using EDFA, there will be ASE noise along the route. Hence the last term in Eq. (4) represents the ASE noise along the fiber, and the first two terms represent the ASE noise due to EDFAs inside the node. We assume that this is as constant, when the wavelengths are centered around f_c . In the system of cascade amplifiers, the notion of sensitivity is not very useful when signal reaching the receiver has already added lot of noise [4]. In this case two parameters that are measured are, the average received signal power, $P(n)$ and received optical noise power $P_{ase}(n)$. The optical signal to noise ratio (OSNR) at node n is given by $OSNR(n) = P(n)/P_{ase}(n)$. By neglecting the receiver thermal noise and shot noise, the relationship between the q -factor and OSNR is given by [4],

$$q(n) = \frac{2\sqrt{\frac{B_o}{B_e}}OSNR(n)}{1 + \sqrt{1 + 4OSNR(n)}}, \quad (5)$$

where $q(n)$ is defined as the quality factor of the link between nodes $\langle n, n+1 \rangle$. Bit error rate of link n is given by,

$$BER(n) = 2 \operatorname{erfc} \left(\frac{q(n)}{\sqrt{2}} \right), \quad (6)$$

where, $\operatorname{erfc}(x)$ is called complementary error function.

C. Assumptions

- 1) In the recursive equations we have chosen the gain of the amplifiers (input/output) to be a constant, i.e., gain saturation effects of the amplifier are not considered.
- 2) We have assumed that q -factor is independent of the wavelength chosen. This assumption is valid when the wavelength spacing is less. Hence the carrier frequency f_c is chosen to be the central frequency of the wavelength band.
- 3) Signal degradation due to cross-talk and non-linearity in fiber have been ignored in the computation of q -factor.

D. Online Evaluation of q -factor using Burst Header Packet (BHP) Signaling

In a manycast scenario, we have the request in the form of (s, D_c, k) , with $|D_c| = m$. In order to identify the best set of k destinations, we need to have a best possible path, both in terms of reduced load and quality (in other words high $q(n)$). Assuming the link to be free, we can route the optical signal. However the link may have a bad q value which in-turn results in high BER. If BER is greater than 10^{-9} then the signal cannot be recovered. Thus by keeping a threshold value, q_{th} for the BER we ensure that the signal received is acceptable. High BER corresponds to low q , so we say optical signal is said to be lost when q falls below q_{th} . Thus, the burst that was assumed to be transmitted by the network layer, cannot be recovered by the core node and is actually lost before reaching to egress node. The BHP used to reserve the channel for the OXC can also be used to make the OXC aware of the q -factor. BHP can incorporate a new field that has q value. Initially, the

q -field is set to a high value, and once BHP reaches the next node this value is updated using the recursive Eqs. (3,4,5). At every intermediate node, the BHP updates the q and checks the condition, $q_{new} > q_{th}$. If this is true the BHP proceeds further, else the burst is said to be dropped. Burst loss due to signal impairment is defined as *Optical-Layer Blocking*.

Successful reception of the optical burst at the egress node is based on two issues, contention and impairments of the link. The manycasting schemes proposed in [2] are modified to consider these two issues and are discussed in the next section.

IV. IMPAIRMENT-AWARE DYNAMIC MEMBERSHIP

In this section we discuss the manycasting schemes proposed in [2] to consider the signal degradation due to the impairments in the fiber. However we only modify the Dynamic Membership (DM) scheme rather than Static Over Provisioning (SOP), because DM is found to out-perform SOP. We describe the scheme as *Impairment Aware Dynamic Membership (IADM)*. This scheme takes into account of burst losses, due to *contentions* and *transmission impairments*.

IADM takes the network status into consideration. Instead of selecting the destinations before the burst is transmitted, we dynamically add the members as possible destinations, depending on contention and quality of the link. Thus IADM will work with distributed version of SPT. The set of k -destinations is tentatively set up at the source node. We do not discard the remaining $m - k$ destinations, but instead they are kept as the child branches at the source node. The algorithm is shown in the next page.

IADM algorithm is explained with an example shown in Fig. 3. Consider the manycast request $(1, \{5, 6, 8, 9\}, 3)$ with signal and ASE powers as shown in Fig. 3. The table in the Fig. 3 shows the number of splits, signal and ASE power at each node. The output of IADM algorithm gives the manycast request at the next-hop node with signal and ASE values. These two values can be used to compute q -factor and thus qualify the outgoing link. The sets \mathbb{V} represent next-hop nodes (or child-nodes) for the Node u , \mathbb{Q}_L represent set of nodes that have low q -factor, and \mathbb{C}_L is the set of nodes that are blocked due to contentions. These sets are initialized to null before the start of the algorithm. When the request arrives, and if $u \in D'_u$ then the burst is received locally and request is updated as shown in the lines 1-3. The set $\{5, 6, 8, 9\}$ is the sorted set of candidate destinations in the non-decreasing order of the hop-distance. Assuming link $\langle 1, 2 \rangle$ is free, \mathbb{V} is updated, and the signal power, ASE power received at Node 2 are computed. Note that there is no split ($|\mathbb{V}| = 1$) and q -factor is computed as in lines 10-12. The condition for threshold is checked and thus the destination set at the next-hop node is updated. Lines 19-20 ensure that the number of destinations at all the child nodes does not exceed k_u , the number of destinations at the current node. The loop in line-5, is executed for all destinations. Hence the next destination in the order of increasing hop-distance is 6. The child node for the current node 1 is 3 and hence link $\langle 1, 3 \rangle$ is checked for contention. If it is free then the split takes places at node 1 and the power is divided equally among nodes

Impairment Aware Dynamic Membership Algorithm

Input: The manycast request (u, D'_u, k_u) arrives at the source node with a candidate destination set D'_u , along with the k intended.

The power inputs for this manycast request are $(P(u), P_{ase}(u))$. For clarity we denote the manycast request by, are the signal and ASE powers at node u .

$(u, D'_u, k_u, P(u), P_{ase}(u))$ where $P(u), P_{ase}(u)$

Output: Manycast request to the next hop node after satisfying the BER constraint.

Initialization: At the source node, the manycast request is of the form

$(s, D'_s, k_s, P(s), P_{ase}(s))$

```

1  if  $u \in D'_u$ 
2  ▷ Update  $D_u$  and  $k_u$ 
3   $D'_u \leftarrow D'_u \setminus \{d'_j\}$ 
4   $k_u \leftarrow k_u - 1$ 
5  ▷ Destination set  $D'_u$  is the non-decreasing
6  order of the hop distance
7  else
8  for  $j \leftarrow 1$  to  $|D'_u|$ 
9   $n_j \leftarrow UNICAST[u, d'_j]$ 
10  if  $(\langle u, n_j \rangle = FREE)$ 
11   $\mathbb{V} \leftarrow \mathbb{V} \cup \{n_j\}$ 
12  for  $i \leftarrow 1$  to  $|\mathbb{V}|$ 
13   $P(v_i) \leftarrow POW\_SIGNAL(P(u), |\mathbb{V}|)$ 
14   $P_{ase}(v_i) \leftarrow ASE\_SIGNAL(P_{ase}(u))$ 
15   $q(v_i) \leftarrow Q\_FACTOR(P(v_i), P_{ase}(v_i))$ 
16  if  $(q(v_i) > q_{th})$ 
17   $D_{v_i} \leftarrow D_{v_i} \cup \{d(v_i)\}$ 
18  ▷  $d(v_i)$  is the destination to be
19  reached through child node  $v_i$ 
20  else
21   $D_{v_j} \leftarrow D_{v_j} \setminus \{d(v_i)\}$ 
22   $\mathbb{Q}_L \leftarrow \mathbb{Q}_L \cup \{d(v_i)\}$ 
23  end
24  end
25  end
26  while  $\sum_{k=1}^j k_{n_k} < k_u$ 
27  do  $k_{n_j} \leftarrow k_{n_j} + 1$ 
28  else
29   $\mathbb{C}_L \leftarrow \mathbb{C}_L \cup \{d_j\}$ 
30  end
31  end
32  end

```

2 and 3 ($|\mathbb{V}| = 2$). Note that ASE power remains unchanged. Thus the new power and q values are computed using lines 10-12. Thus we see that IADM takes into consideration the network status and optical signal quality dynamically for a given manycast request.

V. SIMULATION RESULTS

In this section we present our simulations results. We consider *average request blocking ratio* as performance metric. We define average request blocking ratio as given by [2]. Let f be the total number of requests in the simulation. Consider a manycast request (s, D_c, k) . Let D'_f be the set of destinations which actually receive the data. Then *average request blocking ratio* is given by,

$$\bar{b} = \sum [1.0 - \min(|D'_f|, k)/k] / f. \quad (7)$$

We compare the f results of the dynamic membership (DM) scheme described in [2] with our proposed *impairment aware-dynamic membership*. As DM shows better performance than other schemes like SOP used in [2], we use DM for comparing

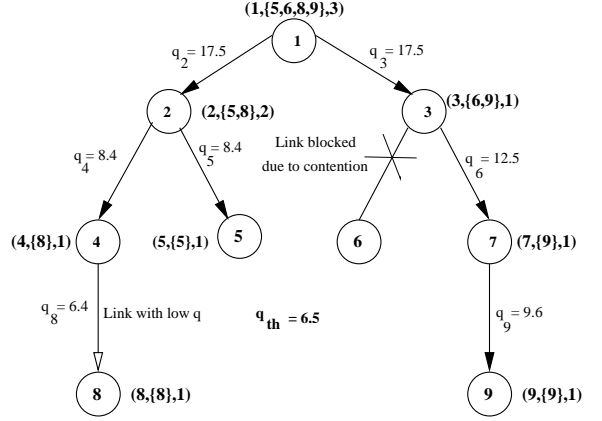

Node	P(n)=Signal Power (mW)	P(n)=ASE Power (mW)	Splits
1	1.00	0.0042	2
2	0.40	0.0110	2
3	0.40	0.0110	1
4	0.16	0.0160	1
5	0.16	0.0160	—
6	—	—	—
7	0.32	0.0160	1
8	0.12	0.020	—
9	0.25	0.020	—

Fig. 3. For a manycast request we show how the IADM works. Thus we see that in spite of having no congestion on the Link $\langle 4, 8 \rangle$, the manycast request is not meet due to the low q -factor. Fiber length between two nodes is taken as 70 kms.

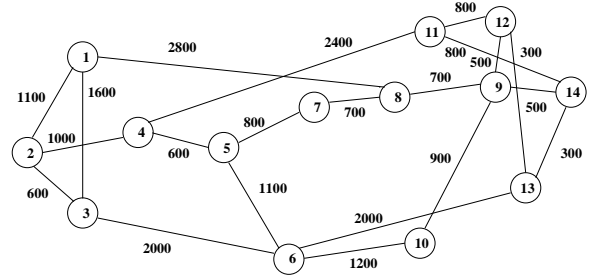

Fig. 4. The NSF network consisting of 14 nodes and 21 bi-directional links (distance in km). These links consists of in-line EDFAs spaced 70 kms apart (not shown in the figure for clarity).

our results. We use notation m/k , to denote the group size of m and k intended destinations. We use NSF network as shown in the Fig. 4 for our simulation studies. All the links in the network are bi-directional and have same transmission rate of 10 Gb/s. Burst arrivals follow Poisson process with an arrival rate of λ bursts per second. The length of the burst is exponentially distributed with expected service time of $1/\mu$ seconds. The network load is then defined as λ/μ . The source and candidate destinations of a manycast request are evenly distributed among all the nodes. There are no optical buffers or wavelength converters in the network. The physical layer parameters used in the simulation model are shown the Table. I. We use DM and IADM with shortest-path tree (SPT). As in [1], [9], we consider the candidate destinations set D_c at small, medium, and large sizes, and the intended destinations is a majority of the group. Three typical configurations, 3/2, 7/4,

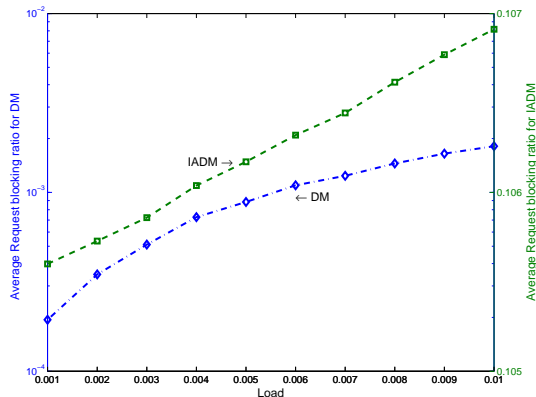

Fig. 5. The blocking performance comparison between regular DM and IADM for manycast configuration 7/4 under low load

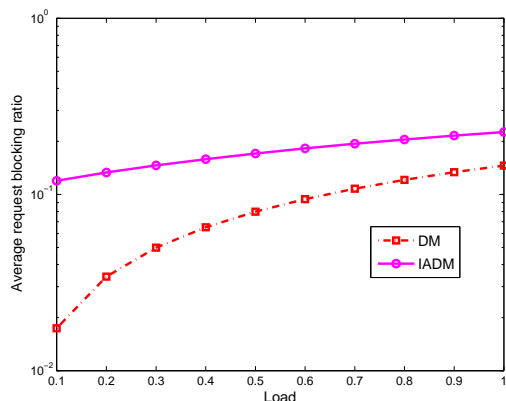

Fig. 6. The blocking performance comparison between regular DM and IADM for manycast configuration 7/4 under medium load

11/6 were used in the simulation. In all the simulations over-provisioning was not considered.

We evaluate the blocking performance for different loads. The graph of average-request blocking ratio versus load under low-load for 7/4 configuration is shown in the Fig. 5. Here we use two different y -axis to compare the performance of DM and IADM. DM represents the blocking due to contention, whereas the IADM represents the overall network blocking, i.e., loss due to contention and high BER. It can be observed from the figure that, under low-load conditions most of the blocking occurs due to the insufficient q . The results show a significant difference in the average-request blocking ratio of DM and IADM under low load. Thus DM is found to under-estimate the blocking. We have also carried simulation for medium load and the result is shown in the Fig. 6. With medium load, difference between the blocking of IADM and DM is lesser than that of low-load. As the load in the network increases most of the blocking occurs due to the contention in the network and hence IADM and DM converges to a common value. Thus under high load conditions as shown in the Fig. 7 IADM and DM converge each other. The results for other manycast configurations such as 3/2 and 11/6 are similar to 7/4.

VI. CONCLUSION

In this paper, we discuss issues of impairment aware many-casting service over OBS networks. By incorporating q -field in the signaling we have implemented an easy way of updating

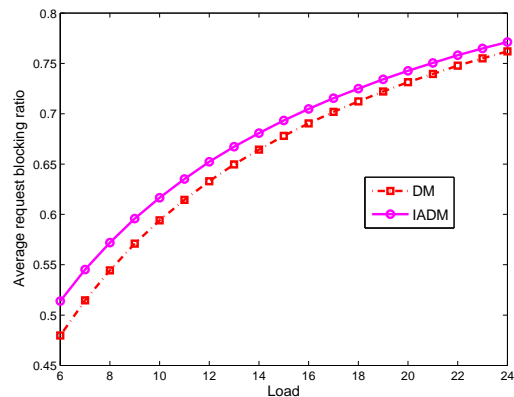

Fig. 7. The blocking performance comparison between regular DM and IADM for manycast configuration 7/4 under high load.

TABLE I

q -FACTOR COMPUTATION PARAMETERS.

Parameter	Value
Channel bit rate (B)	10 Gbps
Optical Bandwidth (B_o)	70 GHz
Electrical Bandwidth (B_e)	$0.7 \times B$
Input power of the signal	1 mW (0 dBm)
Loss of Multiplexer/Demultiplexer	4 dB
Switch element insertion loss	1 dB
Waveguide fiber coupling loss	1 dB
Tap loss	1 dB
Fiber Attenuation Coefficient	0.3 dB/km
Gain of EDFA in MC-OXC (G_{in}, G_{out})	22 dB, 16 dB
ASE factor (n_{sp})	1.5
Planks Constant h	6.63×10^{-34} J-s
Carrier frequency f_c	193.55 THz
P_n in Eq. (4)	$2n_{sp}hf_cB_o$
Spacing between the amplifiers (l)	70 kms
q_{th}	6.5
Number of Fibers/link (N)	2 (bi-directional)

the q depending on the signaling split at each node. This makes the algorithm work in the practical scenario where optical signal degrades due to physical layer impairments. We have accounted for the burst loss in both network layer and physical layer utilizing IADM dynamically. The proposed scheme is verified by extensive simulation results.

REFERENCES

- [1] S. Y. Cheung, and A. Kumar, "Efficient quorum cast routing algorithms," *Proceeding, IEEE INFOCOM*, pp. 840-847, Jun. 1994.
- [2] X. Huang, Q. She, V. M. Vokkarane, and J. P. Jue, "Manycasting Over Optical Burst-Switched Networks," *Proceeding, IEEE International Conference on Communication (ICC)*, pp. 2353-2358, May 2007.
- [3] B. Ramamurthy, D. Datta, H. Feng, J. P. Heritage, and B. Mukherjee, "Impact of Transmission Impairments on the Teletraffic Performance of Wavelength-Routed Optical Networks," *IEEE/LEOS Journal of Lightwave Technology*, Vol. 17, No. 10, pp. 1713-1723, Oct. 1999.
- [4] R. Ramaswami, and K.N. Sivarajan, *Optical Networks*, 2nd Ed., Morgan Kaufmann Publishers, 2004.
- [5] W. S. Hu, and Q. J. Zeng, "Multicasting optical cross connects employing splitter-and-delivery switch," *IEEE Photonics Technology Letters*, vol. 10, No. 7, pp. 970-972, Jul. 1998.
- [6] Y. Xin and G.N. Rouskas, "Multicast routing under optical constraint," *Proceeding, IEEE ICC*, May 2004.
- [7] R. A. Spanke, "Architectures for guided-wave optical space switching systems," *IEEE Communication Magazine*, Vol. 25, pp. 42-48, 1987.
- [8] M. Ali and J. Deogun, "Power-efficient design of multicast wavelength routed networks," *IEEE Journal on Selected Area in Communications*, Vol. 18, No. 10, pp. 1852-1862, Oct. 2000.
- [9] B. Wang, and J. C. Hou, "An efficient QoS routing algorithm for quorum cast communication," *IEEE ICNP*, pp. 110-118, Nov. 2001.