

# 16.100 Introduction to Electrical and Computer Engineering The Future of Wireless Communication

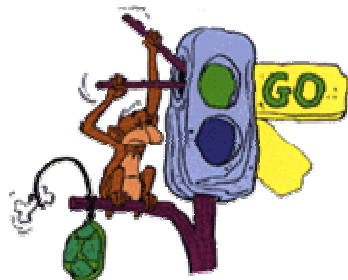

Jay Weitzen

Professor Of Electrical And Computer  
Engineering

Umass Lowell ECE

# The Future For All of US

- Wireless Systems will provide unfettered communications and data mobility.
  - From Station to Station to Person to Person
- The Move to 3G and 4G technology will be disruptive and paradigm changing
  - Fixed Mobile Convergence
  - The handset becomes your data portal (e.g. ipad, iphone, droid, etc)
- “Mobile Broadband Everywhere!”

# Talk Contents

- A brief History of the North American Wireless System
- Generations of Wireless
- The Future of Wireless
- Demonstration of Cellular System Operation
- How To Prepare for A career in Wireless

# A brief History of the Development of Wireless Communication

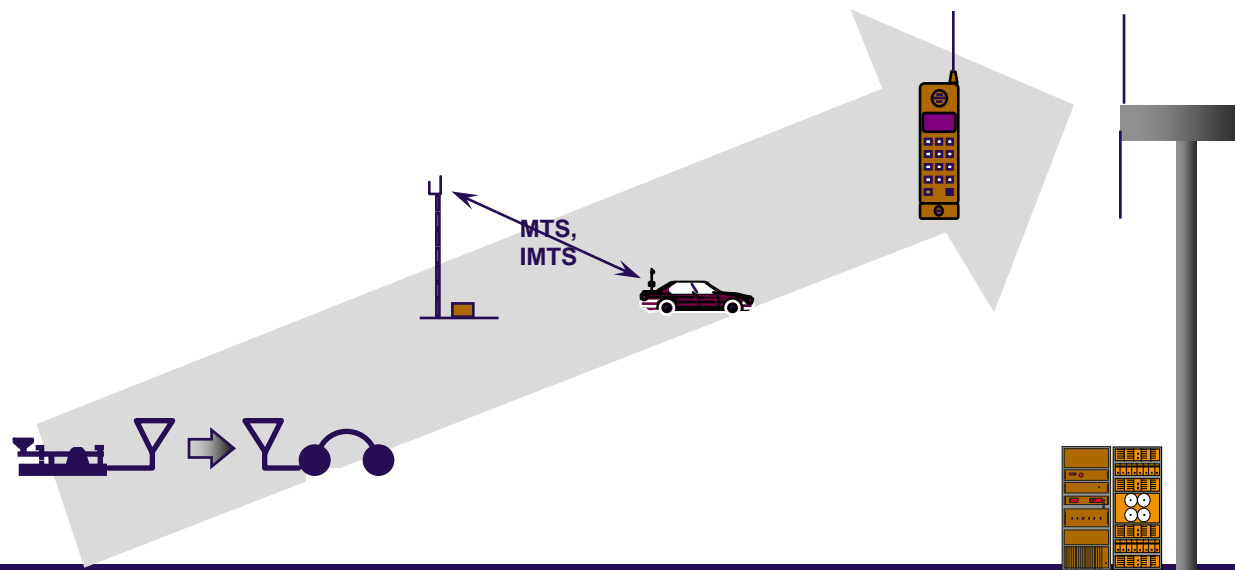

# How Did We Get Here?

## Days before radio.....

- **1680** Newton first suggested concept of spectrum, but for visible light only
- **1831** Faraday demonstrated that light, electricity, and magnetism are related
- **1864** Maxwell's Equations: spectrum includes more than light
- **1890's** First successful demos of radio transmission

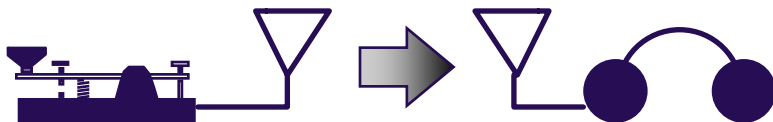
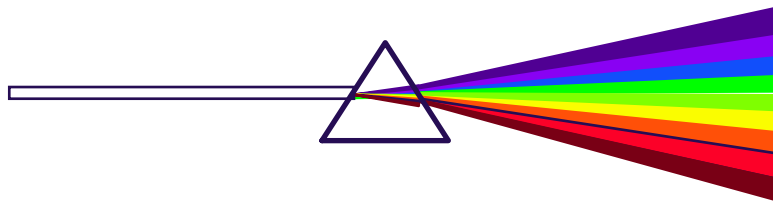

# Telegraphy

- Samuel F.B. Morse had the idea of the telegraph on a sea cruise in the 1833. He studied physics for two years, and In 1835 demonstrated a working prototype, which he patented in 1837.
- Derivatives of Morse' binary code are still in use today
- The US Congress funded a demonstration line from Washington to Baltimore, completed in 1844.
- 1844: the first commercial telegraph circuits were coming into use. The railroads soon were using them for train dispatching, and the Western Union company resold idle time on railroad circuits for public telegrams, nationwide
- 1857: first trans-Atlantic submarine cable was installed



**Samuel F. B. Morse**  
*at the peak of his career*



**Submarine Cable Installation**  
*news sketch from the 1850's*



**Field Telegraphy**  
*during the US Civil War, 1860's*

# Telephony

- By the 1870's, the telegraph was in use all over the world and largely taken for granted by the public, government, and business.
- In 1876, Alexander Graham Bell patented his telephone, a device for carrying actual voices over wires.
- Initial telephone demonstrations sparked intense public interest and by the late 1890's, telephone service was available in most towns and cities across the USA



**Alexander Graham Bell and his phone**  
*from 1876 demonstration*



**Telephone Line Installation Crew**

# Radio Milestones

- 1888: Heinrich Hertz, German physicist, gives lab demo of existence of electromagnetic waves at radio frequencies
- 1895: Guglielmo Marconi demonstrates a wireless radio telegraph over a 3-km path near his home in Italy
- 1897: the British fund Marconi's development of reliable radio telegraphy over ranges of 100 km
- 1902: Marconi's successful trans-Atlantic demonstration
- 1902: Nathan Stubblefield demonstrates voice over radio
- 1906: Lee De Forest invents "audion", triode vacuum tube
  - feasible now to make steady carriers, and to amplify signals
- 1914: Radio became valuable military tool in World War I
- 1920s: Radio used for commercial broadcasting
- 1940s: first application of RADAR - English detection of incoming German planes during WW II
- 1950s: first public marriage of radio and telephony - MTS, Mobile Telephone System
- 1961: transistor developed: portable radio now practical
- 1961: IMTS - Improved Mobile Telephone Service
- 1970s: Integrated circuit progress: MSI, LSI, VLSI, ASICs
- 1979, 1983: AMPS cellular demo, commercial deployment

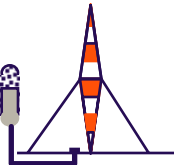
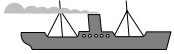

**Guglielmo Marconi**  
*radio pioneer, 1895*

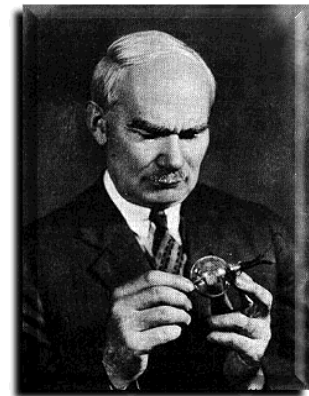

**Lee De Forest**  
*vacuum tube inventor*



# Generations of Wireless

- First Generation, Analog Circuit Switched Voice, Analog Modem/Fax over Circuit Switched Voice
  - AMPS
- 2nd Generation: Digital Vocoder Circuit Switched Voice, Circuit Switched data 16-64 kbps
  - IS-95 A&B, IS-136, GSM (GPRS), IDEN
  - 2.5G low rate packet data comes to wireless (GPRS, EDGE)
- 3rd Generation, Digital Circuit Switched Voice, Packet Switched Broadband Data
  - CDMA 2000 (IS-95C 1xRTT)+ 1xEV-DO, WCDMA (UMTS)
  - 3.5 G, VOIP and QOS come to wireless
- 4th Generation, Broadband Packet Switched Voice (VOIP), Broadband Packet Switched Data MBPS, Fixed Mobile Convergence
  - IEEE 802.16e (wimax), UMTS-LTE, CDMA-2000>LTE

# Early Wireless systems



Wireless Telephone Set (Marconi, 1920)



Early version of a "mobile" phone (Bell Labs, 1924)

# History of Mobile Phones

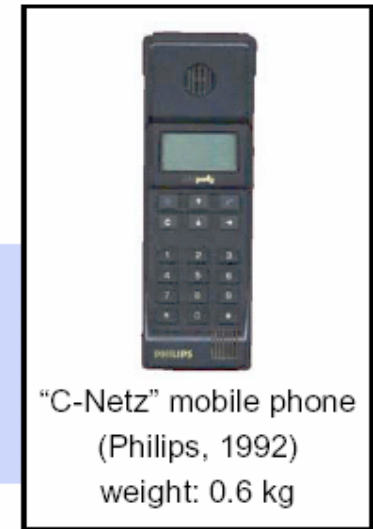

# History of Mobile Phones (cont'd)



GSM phone (Sewon, 2002)  
68 X 38.5 X 22 mm  
weight: 72 g



DECT phone  
(Siemens, 2002)  
weight: 100 g



UMTS mobile phone  
(Sony-Ericsson, 2003)



2007 IPHONE

2010 Evo 4G Phone

# Frequencies Used by Wireless Systems

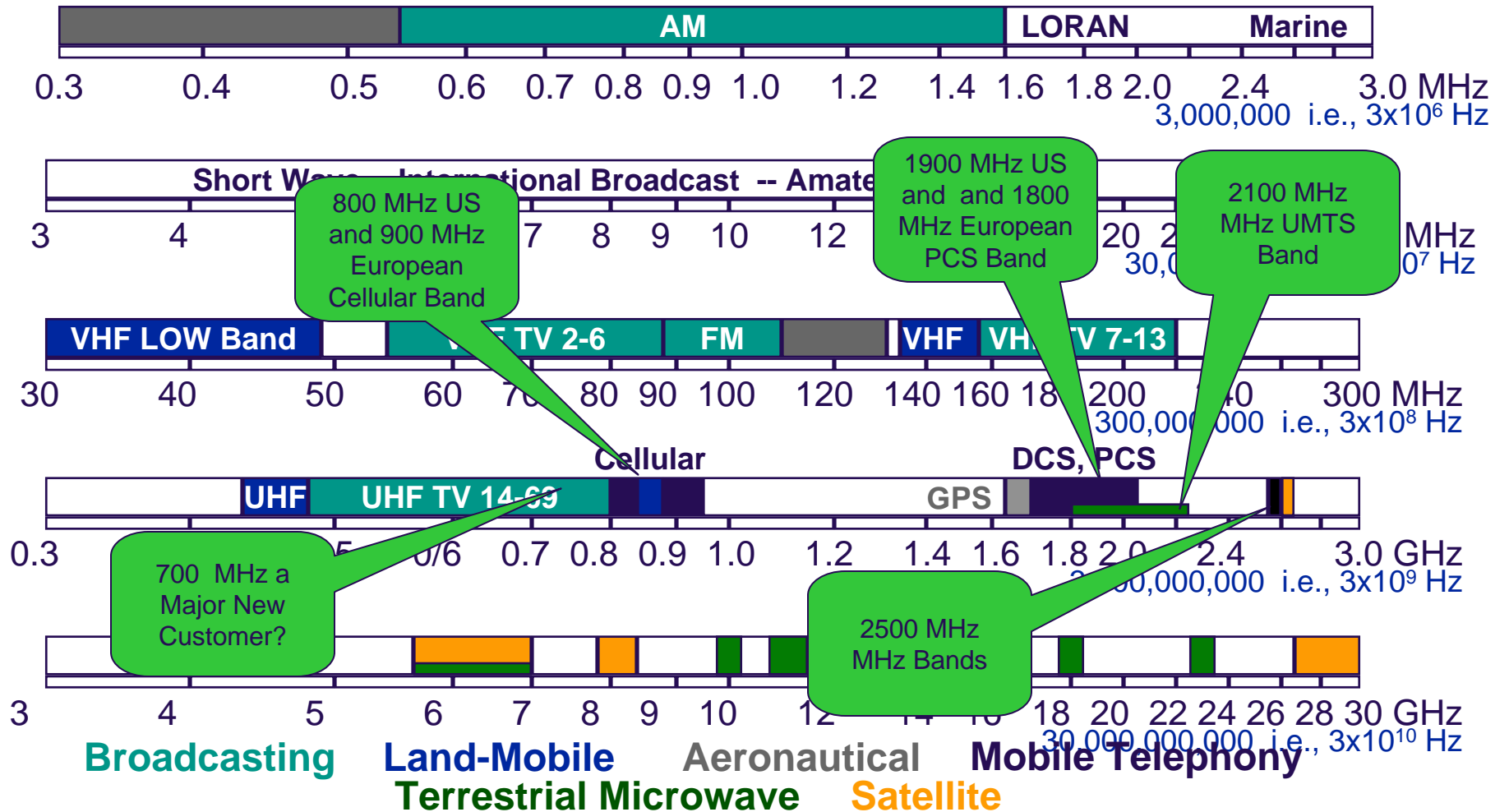

# Development of North American Cellular

- In the late 1970's, the FCC (USA Federal Communications Commission) and the Canadian government allocated 40 MHz. of spectrum in the 800 MHz. range for public mobile telephony.
- FCC adopted Bell Lab's AMPS (Advanced Mobile Phone System) standard, creating cellular as we know it today
  - The USA was divided into 333 MSAs (Metropolitan Service Areas) and over 300 RSAs (Rural Service Areas)
- By 1990, all MSAs and RSAs had competing licenses granted and at least one system operating. Canadian markets also developed.
- In 1987, the FCC allocated 10 MHz. of expanded spectrum
- In the 1990's, additional technologies were developed for cellular
  - TDMA (IS-54,55,56, IS-136) (also, GSM in Europe/worldwide)
  - CDMA (IS-95)
- US Operators did not pay for their spectrum, although processing fees (typically \$10,000's) were charged to cover license administrative cost



# North American Cellular Spectrum



## Ownership and Licensing

**Frequencies used by "A" Cellular Operator**  
*Initial ownership by Non-Wireline companies*

**Frequencies used by "B" Cellular Operator**  
*Initial ownership by Wireline companies*

- In each MSA and RSA, eligibility for ownership was restricted
  - "A" licenses awarded to non-telephone-company applicants only
  - "B" licenses awarded to existing telephone companies only
  - subsequent sales are unrestricted after system in actual operation

# Development of North America PCS

- By 1994, US cellular systems were seriously overloaded and looking for capacity relief
  - The FCC allocated 120 MHz. of spectrum around 1900 MHz. for new wireless telephony known as PCS (Personal Communications Systems), and 20 MHz. for unlicensed services
  - allocation was divided into 6 blocks; 10-year licenses were auctioned to highest bidders

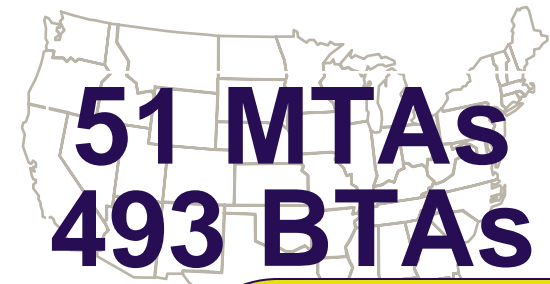

Interesting Factoid:  
Charlie Dolan Uses  
this License as  
Collateral to try to  
Purchase Boston Red  
Sox

## ■ PCS Licensing and Auction Details

- A & B spectrum blocks licensed in 51 **MTAs** (Major Trading Areas)
  - Revenue from auction: \$7.2 billion (1995)
- C, D, E, F blocks were licensed in 493 **BTAs** (Basic Trading Areas)
  - C-block auction revenue: \$10.2 B, D-E-F block auction: \$2+ B (1995)
- Auction winners are free to choose any desired technology

## PCS SPECTRUM ALLOCATIONS IN NORTH AMERICA

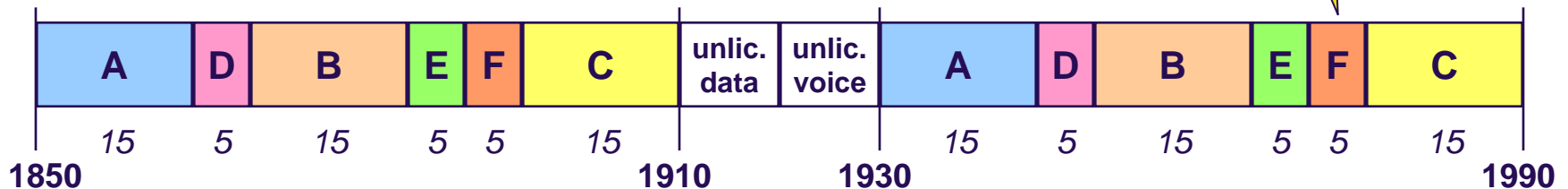



# Major PCS North American Carriers

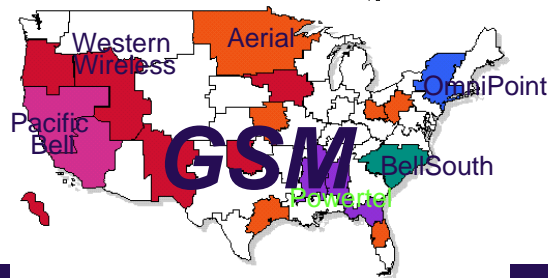
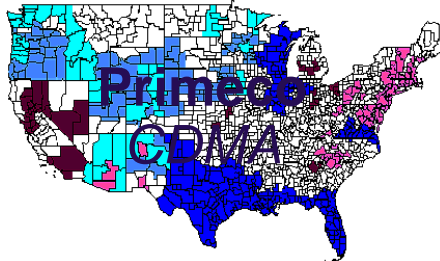
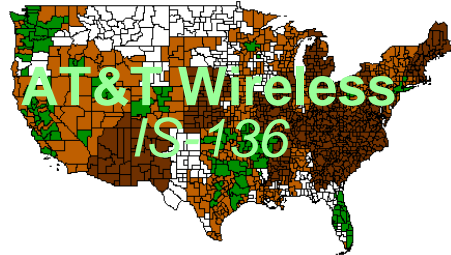
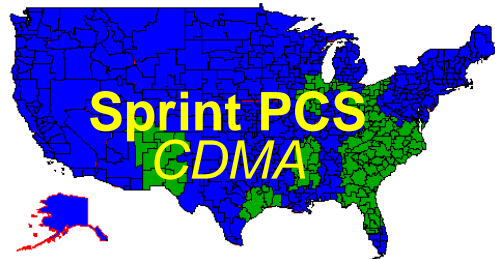

## The Largest Players, Areas, and Technologies

- **Sprint PCS**
  - Partnership of Sprint, TCI, Cox Cable
  - Bid & won in 2/3 of US markets A or B blocks
  - Sprint itself has D and/or E blocks in remaining markets
  - **CDMA**: Mix of Nortel, Lucent, Motorola
  - Merged with Nextel, whose 900 MHz network will be integrated into Sprint network beginning late 2007
- **AT&T Wireless Systems (merged with Cingular)**
  - Bid & won a majority of markets in A&B Blocks
  - will combine and integrate service between its new PCS 1900 systems and its former McCaw cellular 800 MHz. properties
  - **IS-136**: mix of Lucent and Ericsson equipment
  - **GSM/UMTS** conversion underway
- **Verizon**
  - Formed from merger of of Airtouch, US West, Bell Atlantic, NyNex and GTE
  - **CDMA**: Mix of Motorola, Nortel, and Lucent networks
- **GSM Alliance (became T-Mobile)**
  - Western Wireless, OmniPoint, BellSouth, Powertel, Pacific Bell
  - Mix of Ericsson, Nokia, and Nortel networks

# US PCS Bands

C-Block License sells for \$562M in boston

Block Designator	Allocated In Boston: ATT/GSM UMTS	Mobile xmit Frequency	Base xmit In Boston: Sprint
A (mta)	30 (15/15)	1850-1915	1930-1945
D (bta)	10 (5/5)	1850-1865	1930-1945
B (MTA)	30 (15/15)	1865-1880	1930-1945
E (bta)	10 (5/5)	1885-1890	1970
F (bta)	10 (5/5)	1890-1895	1970-1975
C (bta)	30 (15/15)	1895-1910	1975-1990

**In Boston: T-Mobile /GSM UMTS?**

**In Boston: T-Mobile /GSM UMTS?**

**In Boston: Verizon/1xev do**

**In Boston: Cingular, VzW**

# US-MTA's

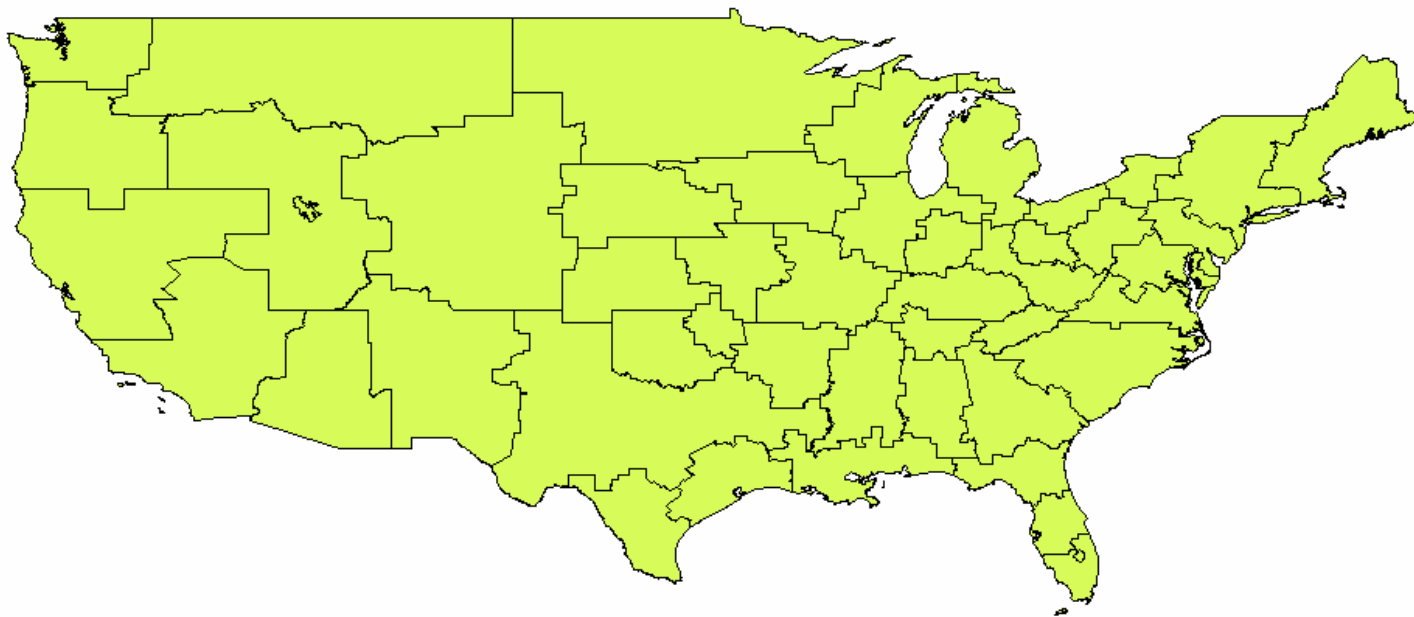

# US-BTA's

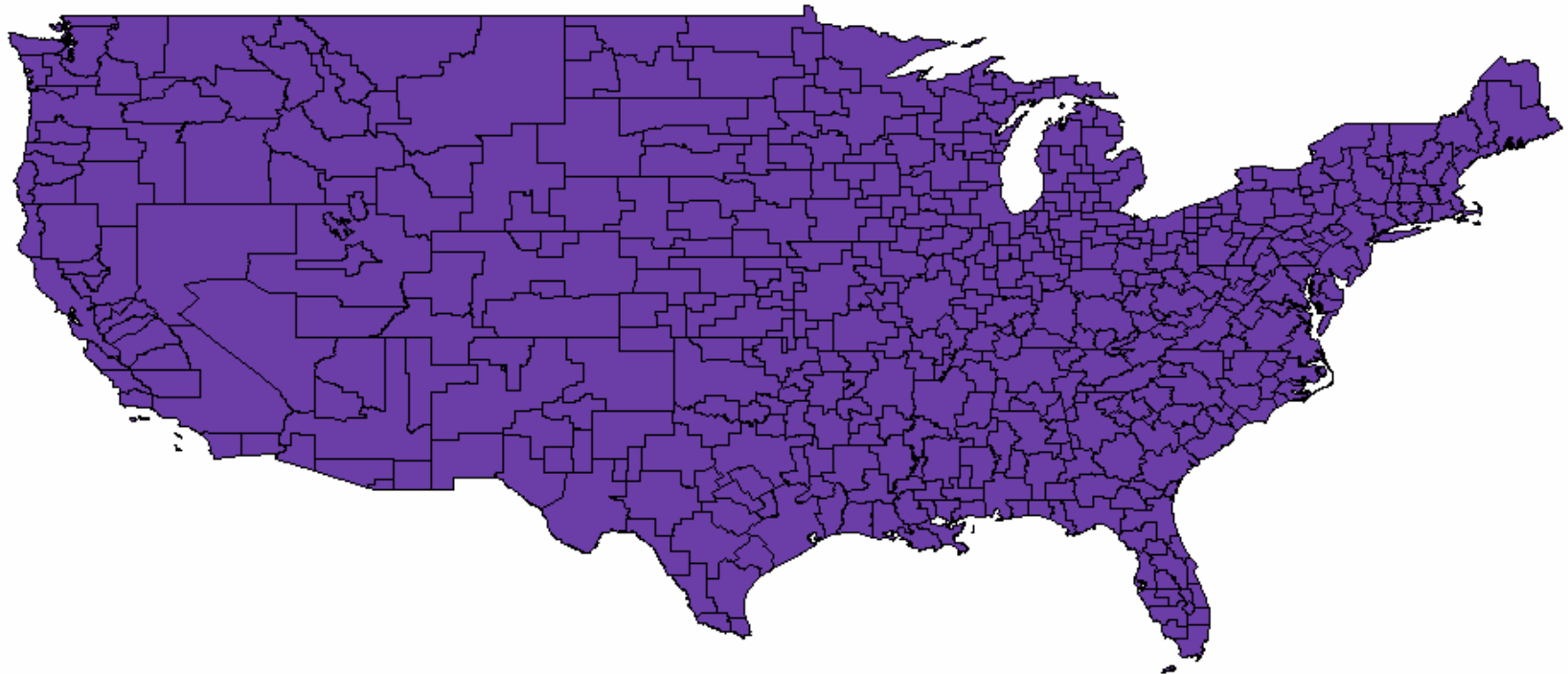

# NE BTA's

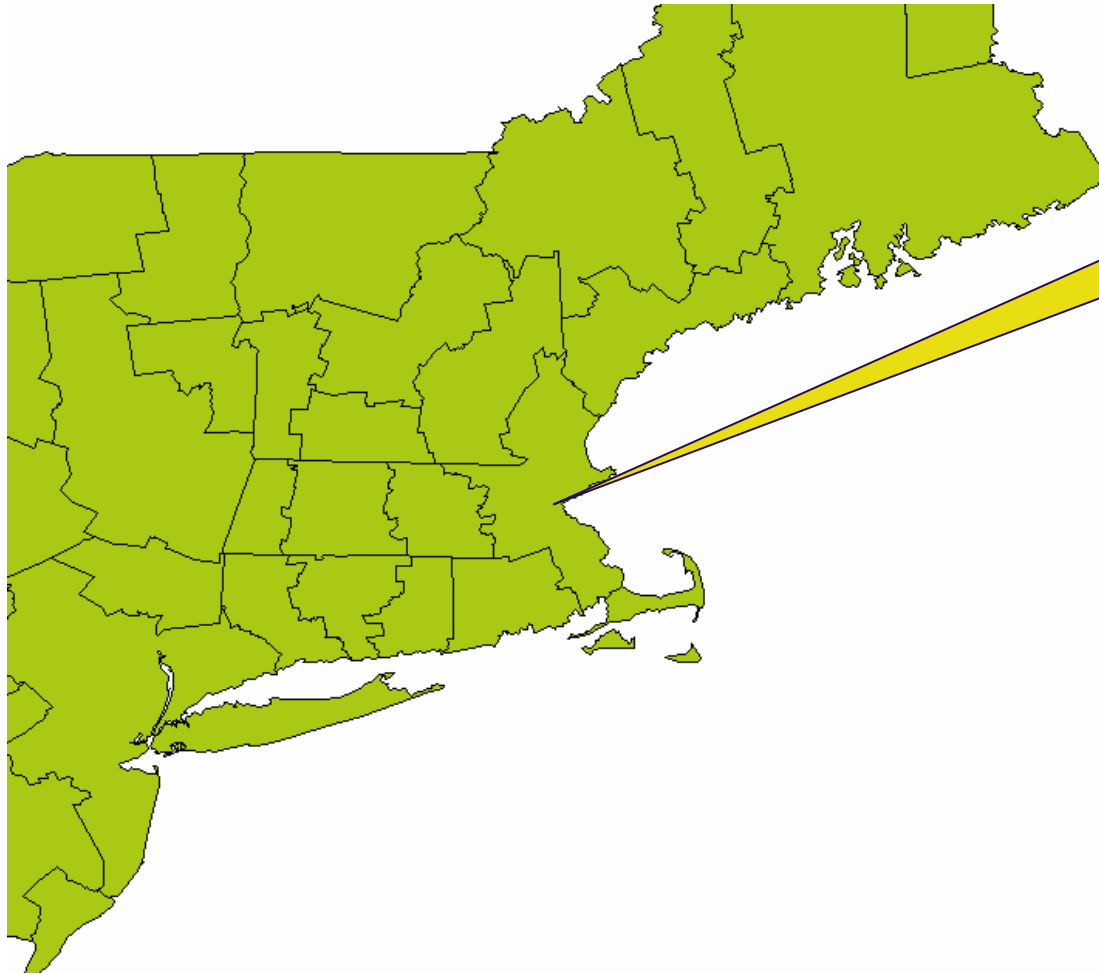

Interesting Factoid:  
Nextwave Wireless  
Bids \$562M for  
Boston License in  
1995

## Consolidation in the Wireless Industry: 4 major players + 3 Regional

- Verizon: Formed from Bell Atlantic Mobile (which formed from NYTel and NETel), GTE Mobilenet, PrimeCo ,and AirTouch Mobile (CDMA)
- ATT/Cingular (GSM, UMTS, IS-136)
- Sprint/Nextel (CDMA/Iden)
- T-Mobile (absorbed most of “gsm alliance” including VoiceStream, Omnipoint, and Western Wireless)

# Consolidation in Wireless Industry (cont'd)

- 2<sup>nd</sup> Tier Regional Carriers
  - US cellular
  - Leap
  - Alltel

# What Makes Up A Modern Wireless Network?

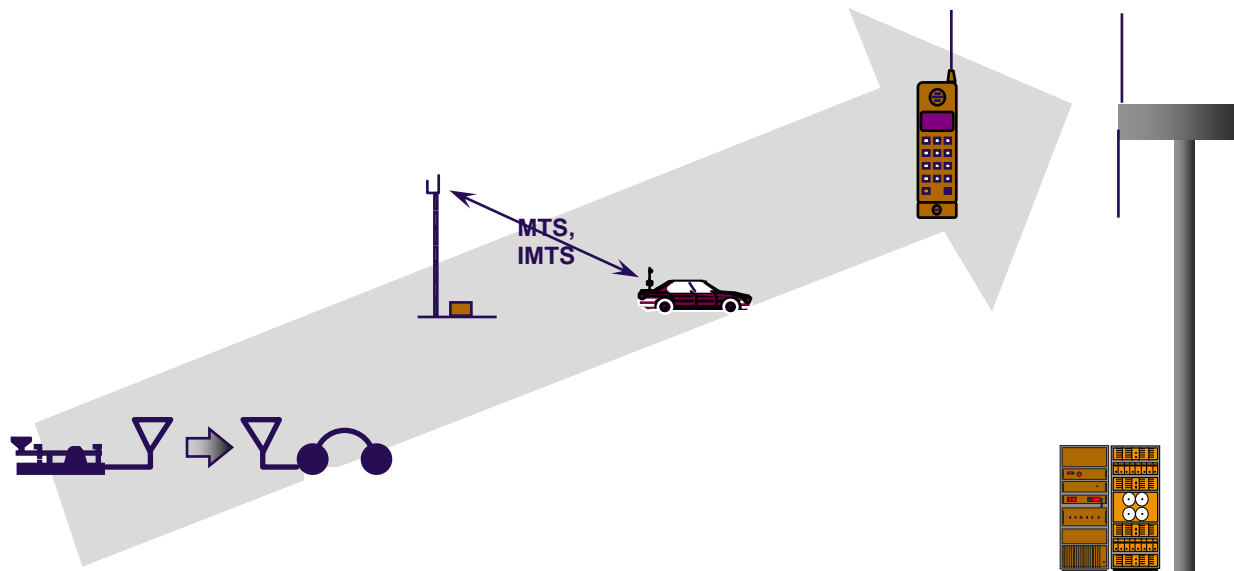



# Major Elements of A Wireless System

- Mobile Terminal
- Access Point (a.k.a. Base station, bts)
- Mobility Manager (a.k.a. BSC, RNC)
- Service Termination Point (MSC, PDSN/SGSN)

# Example: NORTEL CDMA System Architecture

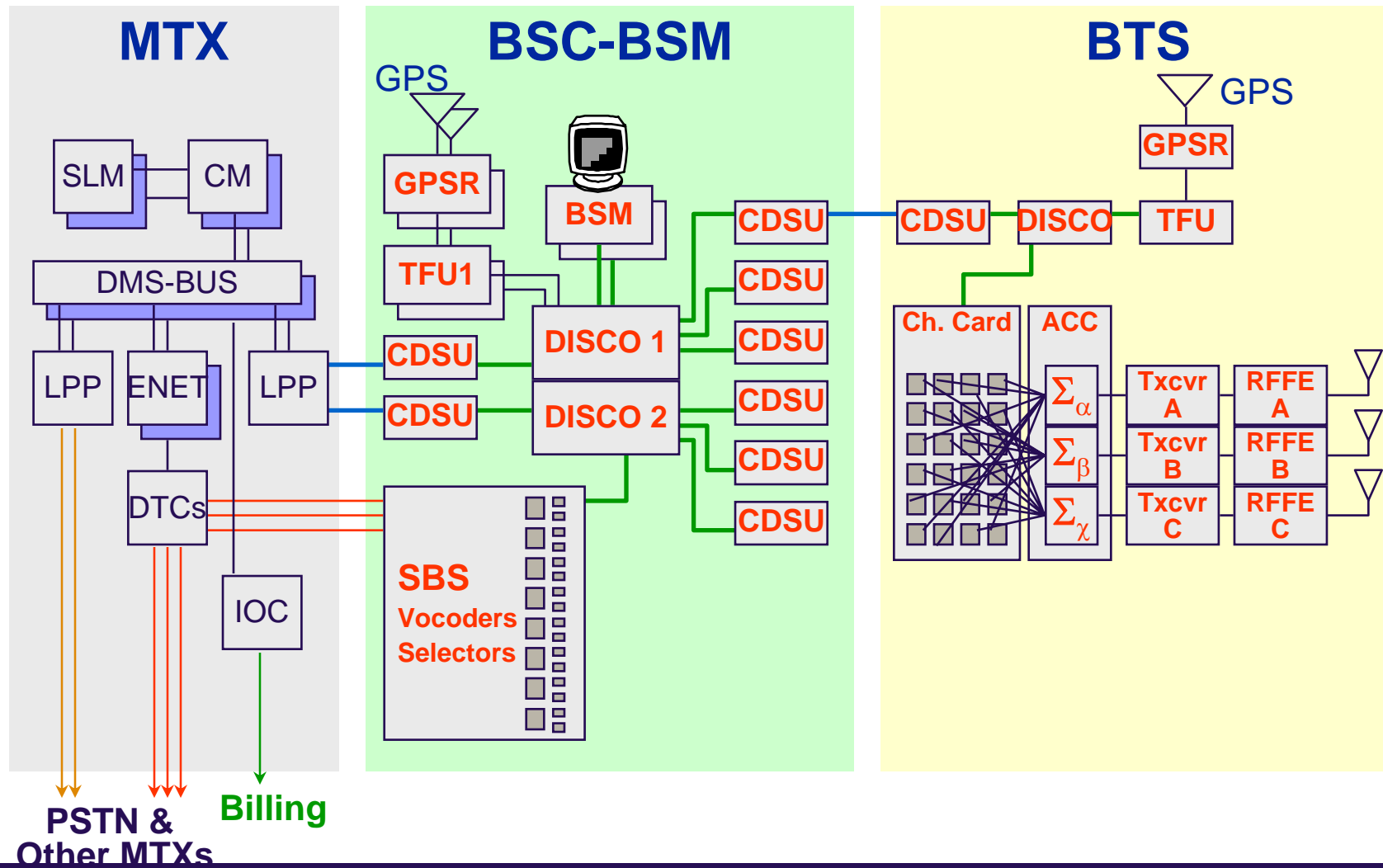

# Signal Flow: Two-Stage Metamorphosis

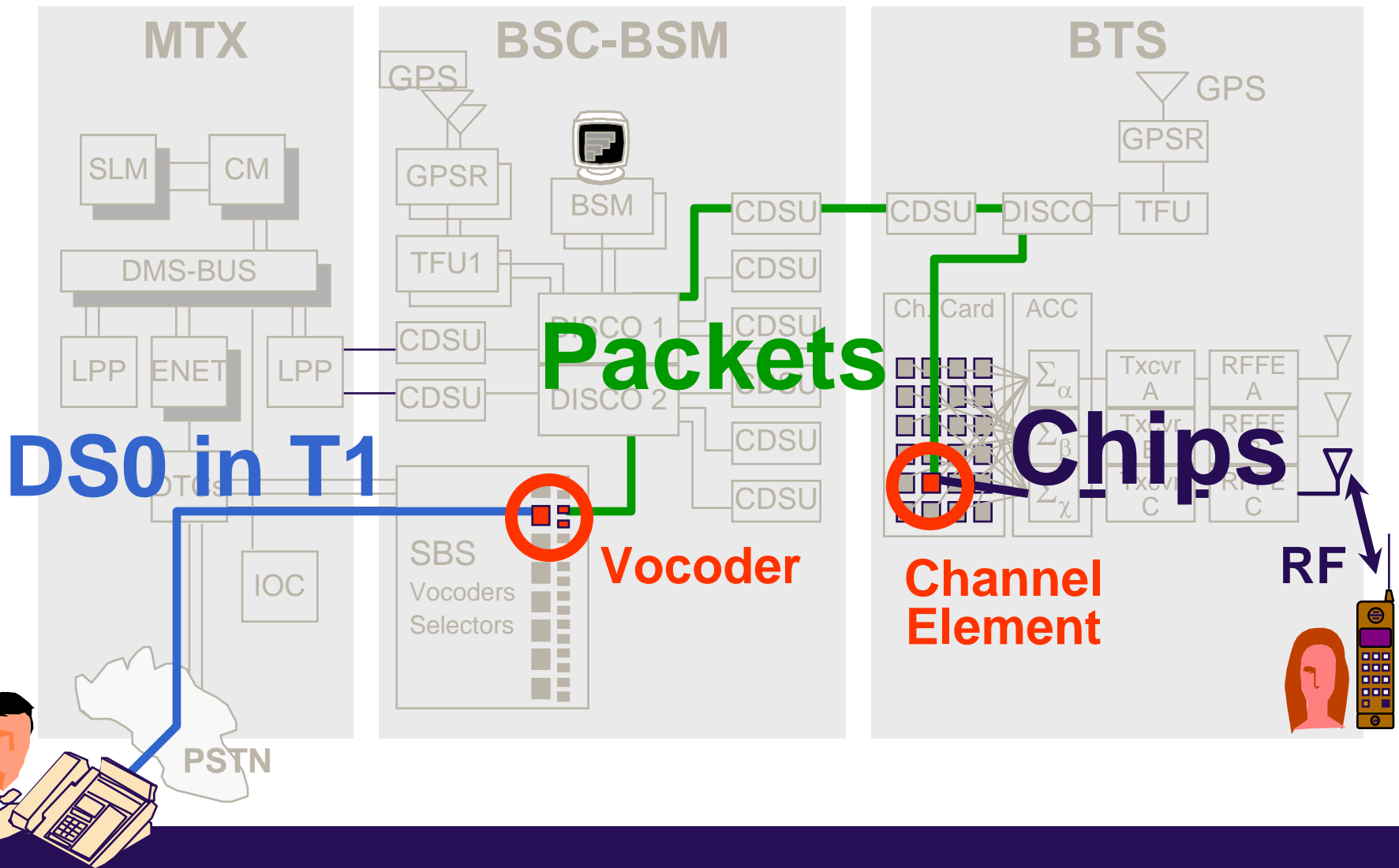

# Architecture: The MTX

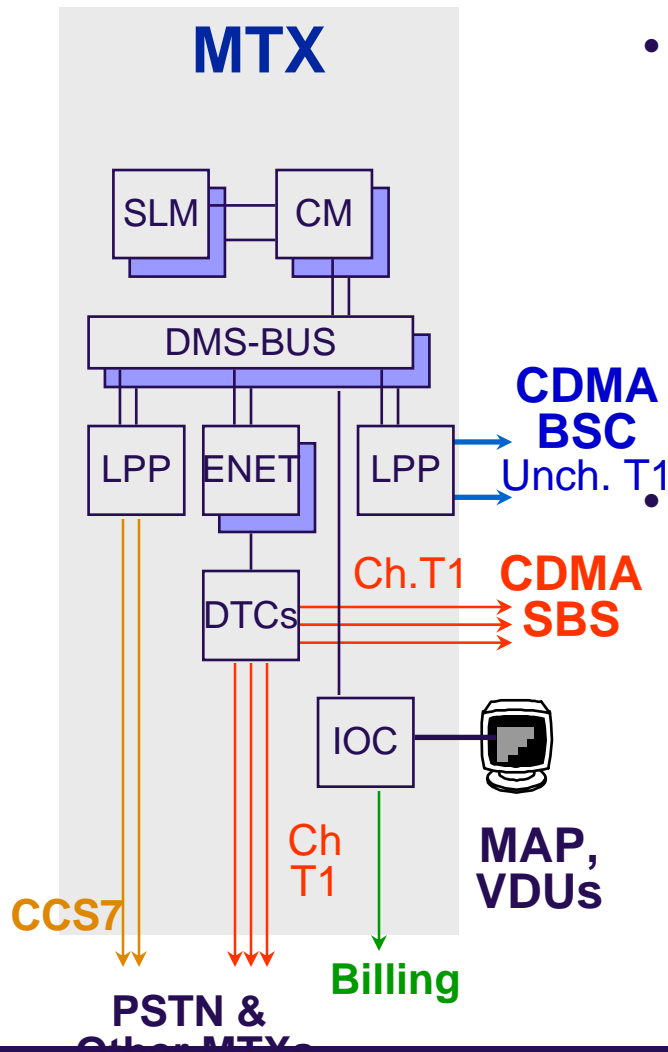

- Primary functions
  - HLR-VLR access
  - Intersystem call delivery (IS-41C)
  - Inter-MTX handover (IS-41C)
  - Billing Data Capture
  - Calling Features & Services
  - Collecting System OMs, Pegs
- High reliability, redundancy

# Architecture: The BSC

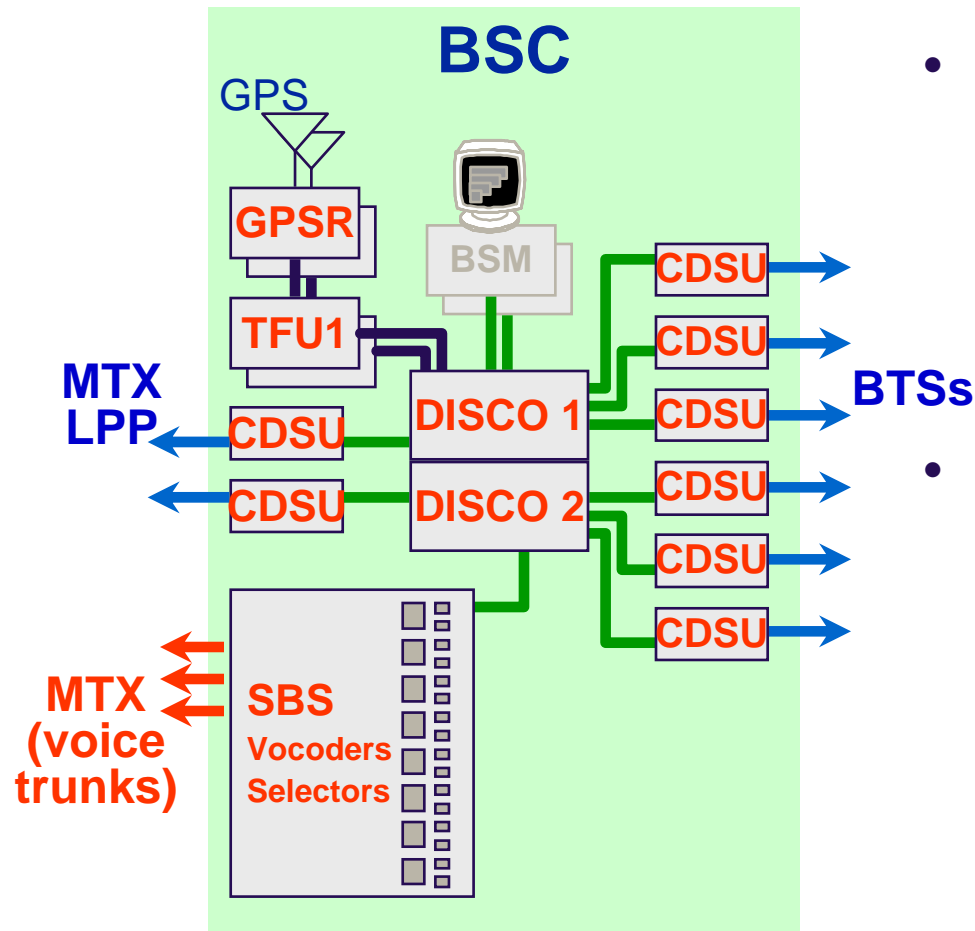

- Primary functions
  - vocoding
  - soft handoff management
  - FER-based power control
  - routing of all traffic and control packets
- Scalable architecture
  - expand SBS to keep pace with traffic growth

— T1 channelized (24 DS0)

— T1 unchannelized

— BCN link (HDLC)

# Architecture: The BTS

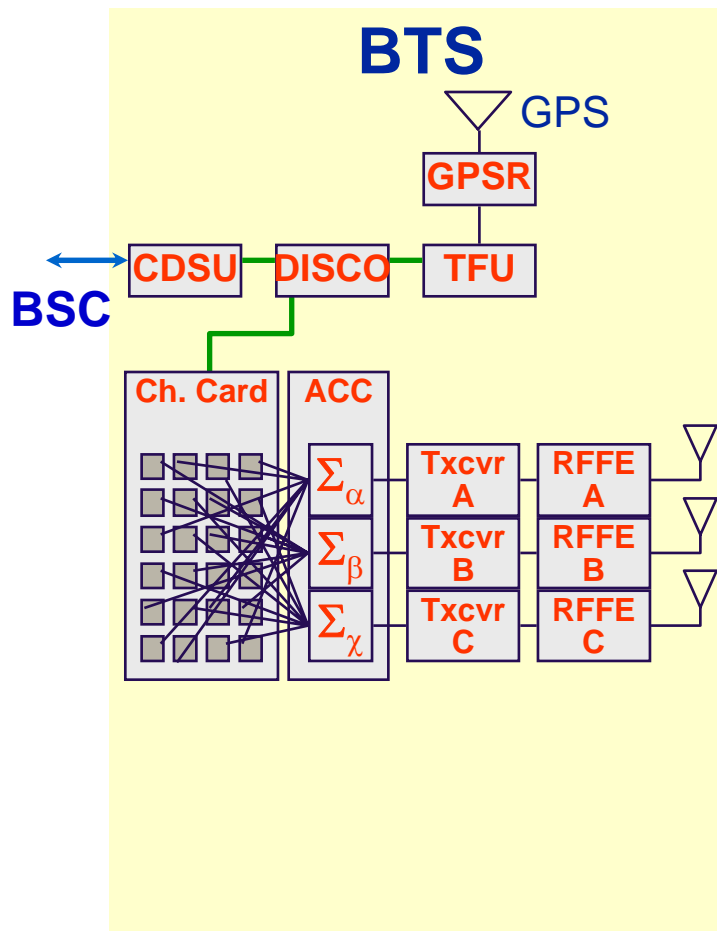

- Primary function: Air link
  - generate, radiate, receive CDMA RF signal IS-95/J.Std. 8
  - high-efficiency T1 backhaul
  - test capabilities
- Configurations
  - 1, 2, or 3 sectors
  - 800 MHz.: indoor
  - 1900 MHz.: self-contained outdoor, removable RFFEs
  - future: 1900 MHz. indoor, 800 & 1900 multi-carrier options

# Architecture: The BSM

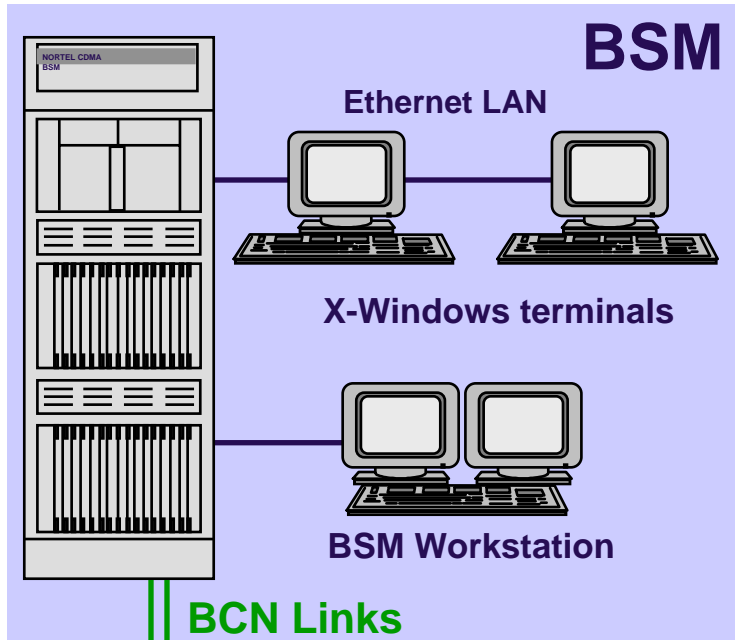

- Primary functions: OA&M for CDMA components
  - Configuration management
    - BSC, BTS configuration and parameters
  - Fault management
    - Alarm Reporting
  - Performance management
    - interface for CDMA statistics and peg counts collection
  - Security management
  - Unix-based

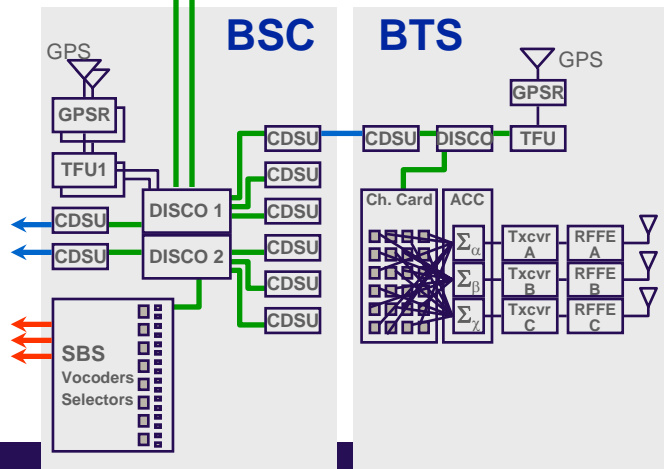

# Mobile Terminal

- Also called Access Terminal (AT, data card, phone, PDA, etc)
- Transceiver (rx and tx)
- User Interface (keyboard and display)
- Implement UE airlink protocols
- Terminate the Application layer protocol



# What's In a Handset?

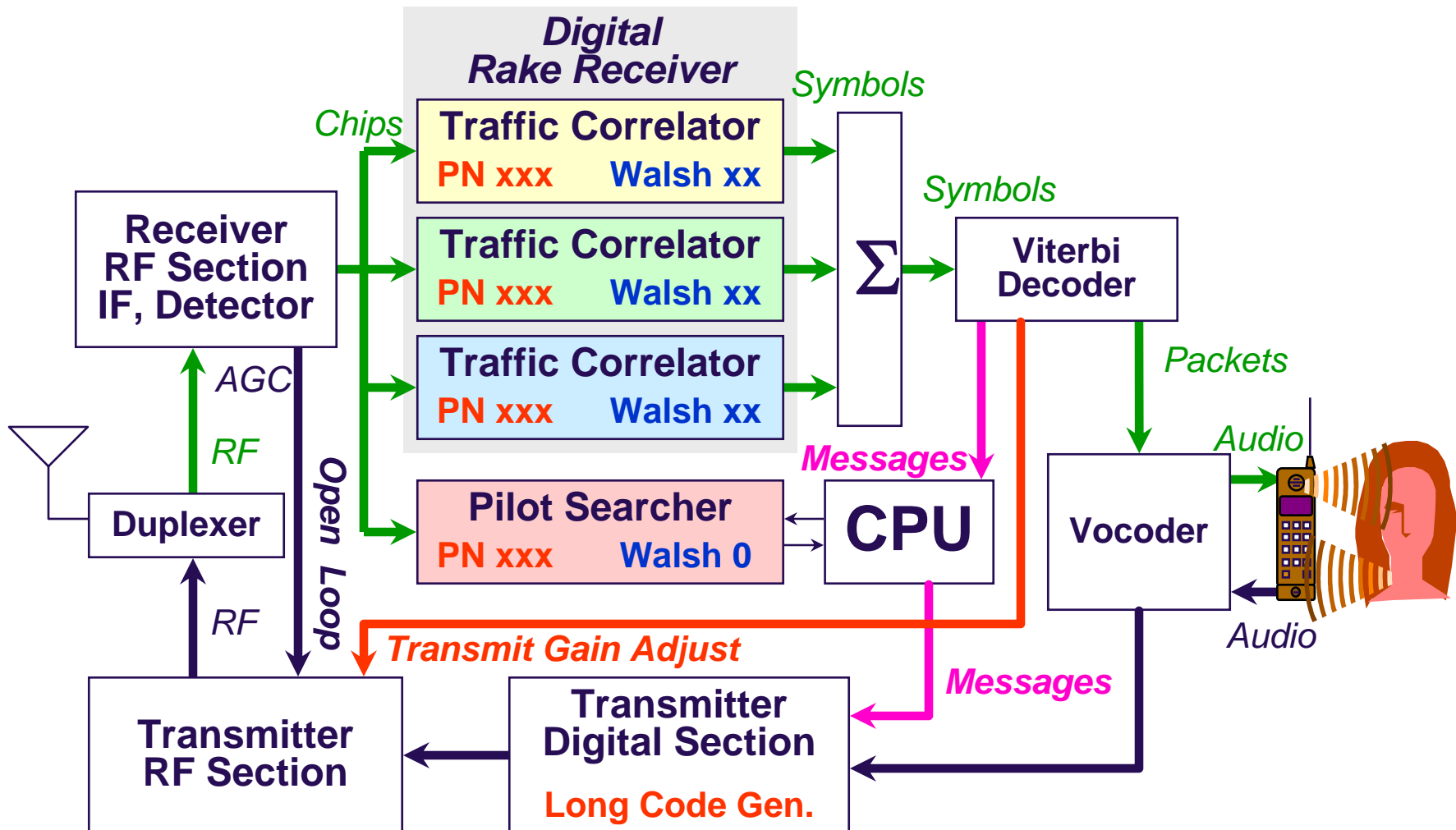

## BTS/AP Functions

- Implement the Airlink protocol (e.g. wifi, wcdma, cdma-2000)
- Communicate with the mobility management system (e.g. BSC/RNC)
- Provide OA&M data

# The Future of Wireless Coming to you!

- QOS Enabled Services Over wireless
  - Next Generation Push to Talk Services
  - Video Telephony
  - Interactive Gaming between Cell Phones
  - Voice Over IP
- Fixed Mobile Convergence
  - Wifi/Personal BTS at home, Macro Cellular Network

# Fixed Mobile Convergence

**3G Macro-Cellular  
Overlay Network**

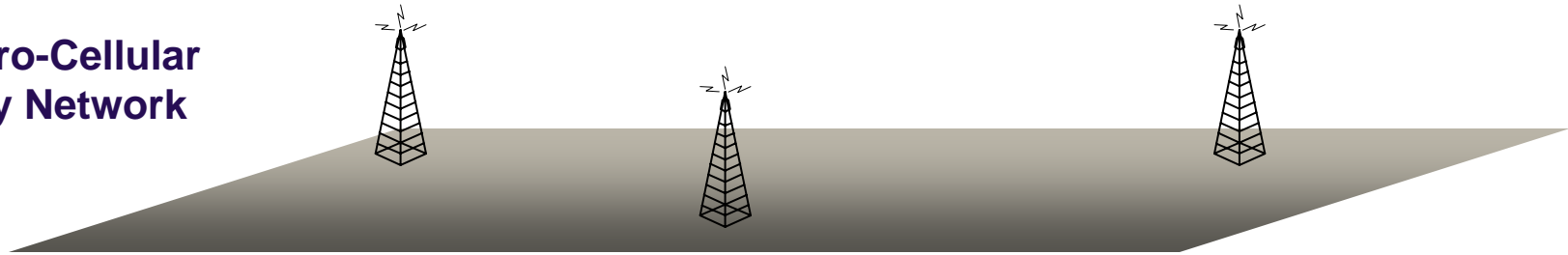

**Home AP  
Underlay Network**

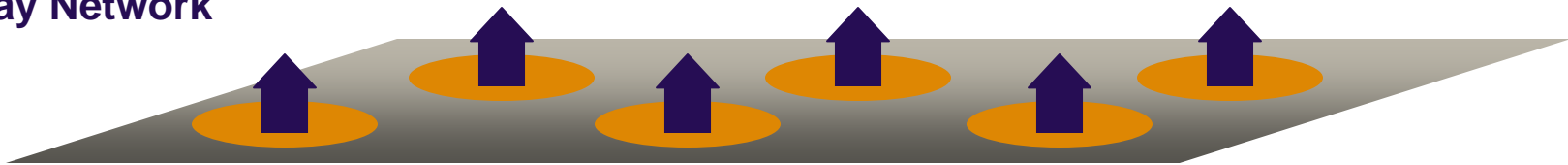

- Overlay network – Outdoor coverage & mobility. Operator bears cap-ex and op-ex
- Underlay network – Inbuilding coverage. Consumer shares cap-ex and op-ex

# Femto Cells and FMC

3GPP2 Compliant PDIF – Security Gateway and Mobile IP Foreign Agent



## Picasso CDMA Femto Cell

1xRTT & EVDO. 6 Users.  
Integrated BSC/RNC/PDSN



*Existing handset*

DSL, Cable, Fiber  
IP Network

Service Activation

Network Planning

TR-069 Device  
Management

## Picasso Service Manager

Activation, Provisioning & Remote Management

### Value Proposition

- *Creates home phone service*
- *Superior user experience*
- *Off-loads macro network*

# Emerging Careers in Wireless

- Each box in the new architecture
- Wireless Service Providers (can you hear me)
- Applications Development
- For more Information
  - Jay Weitzen, Ball 411
  - [Jay\\_weitzen@uml.edu](mailto:Jay_weitzen@uml.edu)

# Preparing for Future Careers in Wireless

- Basic Courses:
  - 16.362 (signals and systems)
  - 16.363 (probability and random signals)
  - 16.460 (electromagnetics)
- Elective/Advanced courses
  - Wireless Communication
  - Communication Theory
  - Antenna Design
  - RF Design
  - Digital Signal Processing
- Programming Classes



YABBA DABBA DOO!  
Thank You for Attending