

Electrogravimetry

(Controlled Potential Electrolysis)

- Apply potential to cause a soluble species to reduce or deposit on a solid electrode

e.g., reduce Cu^{2+} onto Pt cathode

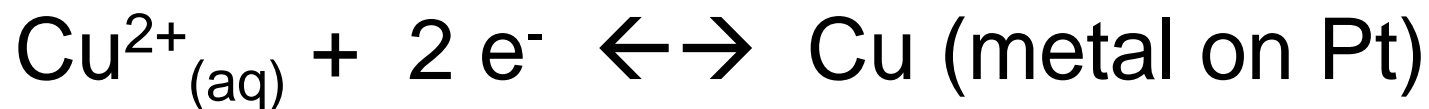

- Change in weight of dried cathode before & after deposition = amount of Cu in sample
- Assumptions:
 - All Cu is plated out
 - Nothing else plates out

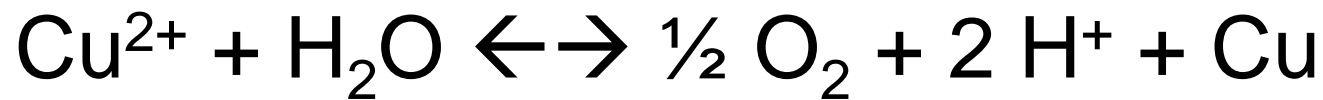
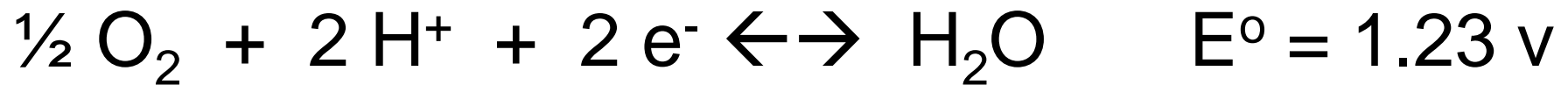

For zero current $E_{\text{cell}} = E_{\text{Cu}} - E_{\text{O}_2, \text{H}_2\text{O}}$

Use Nernst Equation with E° 's & concentrations

$$E_{\text{cell}} = \left(0.34 - \frac{0.059}{2} \log \frac{1}{[\text{Cu}^{2+}]} \right) - \left(1.23 - \frac{0.059}{2} \log \frac{1}{(P_{\text{O}_2})^{0.5} [\text{H}^{+}]^2} \right) = -0.91 \text{ v}$$

- Apply potential more negative than -0.91 v to force system to reach an equilibrium where $[\text{Cu}^{2+}]$ is small (like 99.9% lower than the approximate starting concentration)
- Choose cathode potential to reduce equilibrium $[\text{Cu}^{2+}]$ to any desired value
- Must be cautious not to set potential too far negative to make sure nothing else is reduced
- Normally set conditions so that reduction is complete in a reasonably short period of time

Cell for Electrogravimetry

Pt Electrodes

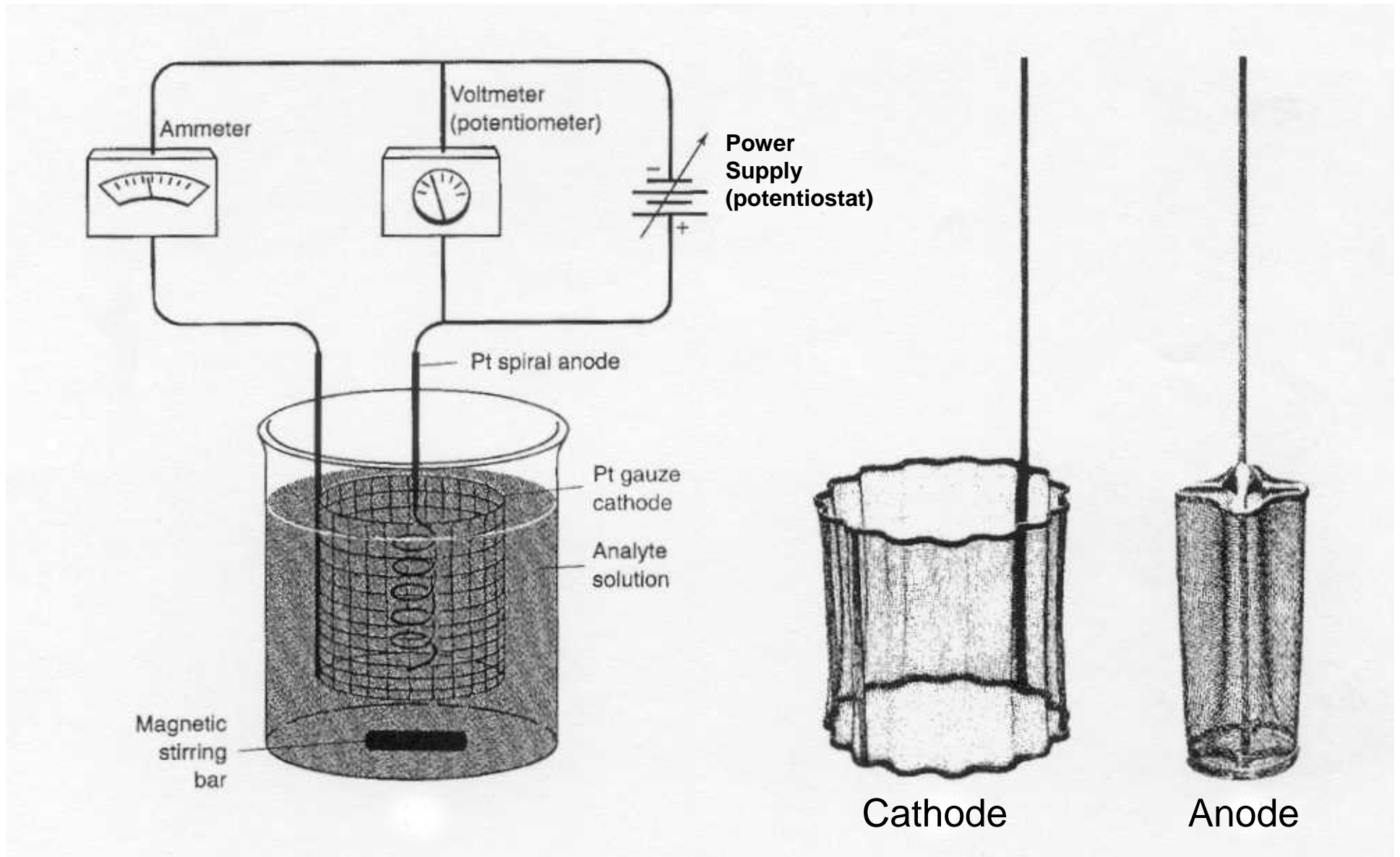

Problem with simple electrogravimetry system is that the potential of the cathode is not accurately known

$$E_{\text{applied}} = E_{\text{cathode}} - E_{\text{anode}} - E_{\text{IR}} - E_{\text{overvoltage}}$$

E_j is insignificant and can be ignored here

Don't know the magnitude of E_{IR} or $E_{\text{overvoltage}}$ & E_{IR} changes throughout experiment

A similar problem exists at the anode since

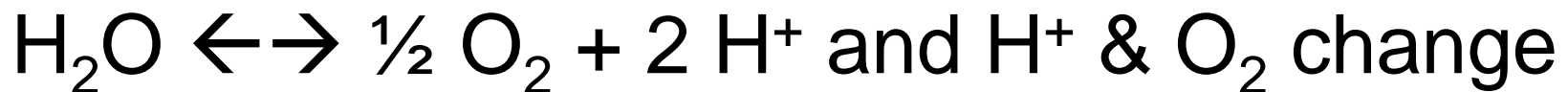

and H^+ & O_2 change during electrolysis so anode potential change

Much of this problem can be eliminated by using a three electrode system

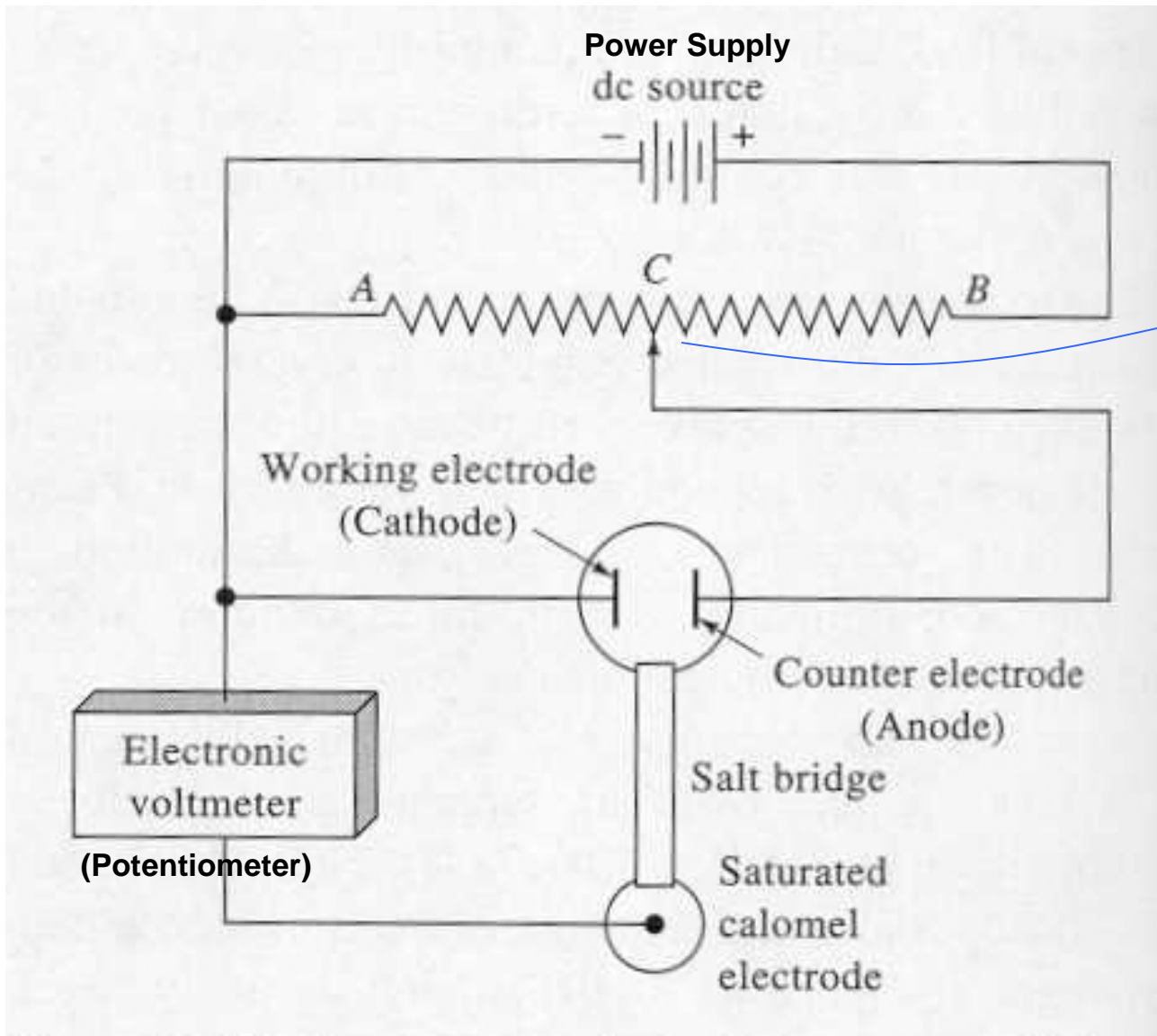

Use potentiometer to measure potential of cathode relative to reference electrode then manually adjust slidewire contact to hold E_{cathode} at desired value. This operation must be repeated at intervals during the electrodeposition because the current changes with conc.

Bulk current still flows from cathode to anode, but anode potential is no longer important.

Three Electrode Configuration

- 1) Reference electrode – maintains fixed potential despite changes in solution comp.
- 2) Working electrode – electrode of interest which is the cathode in this system
- 3) Counter electrode (Auxiliary electrode) – third electrode taking most of current flow (acts as current sink)

Advantages of 3 electrode system

- 1) Changes in concentration at counter electrode are not important, no effect on working electrode potential
- 2) No current flows through reference → no IR drop (its potential is constant)

Applications of Electrogravimetry

(Controlled Potential Electrolysis)

- 1) Quantitative analysis (electrogravimetry) – very accurate & precise, weighing is the only measurement operation, can control degree of completion for the deposition reaction by proper choice of potential, some degree of selectivity using potential
- 2) Separations – separate one species from another in solution by selectively plating it out and removing it from solution. This method is used to remove interferences particularly in electrochemical methods

3) Preconcentration – plating out metals from a large volume of solution (≥ 1 L) onto a small electrode effectively increases their concentration. Can also reoxidize metals back into a small volume of solution (e.g., 1 mL) & the ratio of volumes gives preconcentration factor (i.e., 1000). Can also use other methods for analysis of metal on solid electrode surface (e.g., AA, ICP, XRF, XPS).

4) Electrosynthesis (controlled potential electrolysis) – used by organic chemists to perform oxidation or reduction reactions at bench scale. Take advantage of ability to control potential & produce any oxidizing or reducing strength desired.

5) Purification – to remove trace metals from reagents by plating them out of solution onto

a large Hg pool electrode.

This cell can also be used for electrosynthesis, etc.

